

Your expert for
vibration insulation and
machine installation
technology

GOOD VIBRATIONS

AT BILZ VIBRATION TECHNOLOGY AG, WE ARE EXPERTS IN VIBRATION INSULATION FOR INDUSTRY AND RESEARCH. THERE IS BARELY ANY VIBRATION ENGINEERING PROBLEM THAT WE CANNOT SOLVE.

OUR COMPANY HISTORY

1985

Company is established

1989

Creation of a world-wide distribution network with its first branches in France, Austria, Switzerland, Taiwan, Korea and the USA

1995

Move to the current company headquarters at Böblinger Straße 25 in Leonberg

2006

Change to public limited company

WE WORK FOR THESE INDUSTRIES

- ✓ Machinery / plant construction
- ✓ Industrial measuring technology
- ✓ Semiconductors
- ✓ Research / laboratories
- ✓ Automotive
- ✓ Construction / architecture
- ✓ Pharma / medical technology



OUR FAMILY BUSINESS WAS BUILT ON THESE THREE PILLARS



1

UNRIVALLED PRODUCT RANGE

Our product range covers nearly all applications in industry and research: from simple insulation pads for vibration insulation through levelling elements for vibration-insulated machine installation to vibration-insulated laboratory tables. No matter whether you need a forging hammer to be decoupled with insulation composite pads or you are in the semiconductor industry and want your highly sensitive machines to be air-mounted - there is barely any vibration problem that we cannot solve for you.

2

WE'LL FIND THE SOLUTION - INCLUDING FOR YOU!

The right vibration technology for your application, whether off the shelf or as a custom-made product - that's what we focus on. Our products are only one part of the solution. The other part is our experienced staff who enthusiastically develop new concepts for you. Together we will find the best way for you - we promise!



3

SERVICE - THE WAY YOU NEED IT

We are a system supplier and project partner offering all-round service: From problem analysis and the planning phase of a project to installation, commissioning and after-sales support - with us you get everything from a single source. Our distribution network enable us to offer you our expert advice, services and, of course, our vibration insulation solutions around the world.



FOCUSED ON PARTNERSHIP

NO MATTER WHETHER YOU ARE A LARGE INTERNATIONAL CORPORATION OR A REGIONAL COMPANY: WE AT BILZ VIBRATION TECHNOLOGY AG ARE THE RIGHT PARTNER FOR YOU. PARTNERSHIP FORMS THE BASIS OF OUR CORPORATE CULTURE AND OUR VALUES.

1

WHAT DO WE WANT? FOR YOU TO BE COMPLETELY SATISFIED.

All our actions are driven by the need to see our customers satisfied. To achieve this, we treat our customers and business partners with respect and in a spirit of partnership. We understand their requirements, provide competent advice and work out the optimum solution together. Highest product quality, fair prices and best service form the basis of our customer focus.

2

WE ARE TRUE TO OUR WORD. WE ARE RELIABLE.

We stand by our agreements and commitments. Because that's how trust is built. We believe that trusting cooperation with customers and business partners is the most important foundation for business success.

3

WE FIND THE BEST SOLUTION FOR OUR CUSTOMERS.

We will not settle for any less. What could such a solution look like? It must display maximum performance and at the same time be cost-efficient. We want our customers to be successful in the long term and to benefit from their competitive edge. Aspects of sustainability and environmentally aware actions are becoming more and more important for us and are also increasingly being incorporated into our work.

4

WE ARE FAST AND HAVE SHORT ROUTES.

Short response times are important success factors for our customers in manufacturing and research. The route to our large warehouse directly at our company headquarters is also short. That's how we prevent bottlenecks and procurement issues.

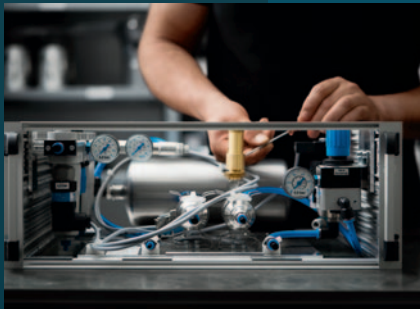

CONTENT

About the company	2-5
Insulation pads	6-13
Levelling elements	14-21
Precision levelling wedges	22-33
Horizontal elements	34-35
Air springs	36-47
Mechanical levelling systems	48-51
Electronic levelling systems	52-53
Active vibration insulation	54-57
Table platforms	58-59
Vibration-insulated tables	60-66
Company headquarters and sales partners	67

INSULATION PADS

THE PROVEN ECONOMIC SOLUTION FOR VIBRATION INSULATION IN MANY INDUSTRY SECTORS



You can also find all information on our insulation pads on our website.

Manufactured from a precisely defined combination of nitrile rubber and cork particles, embedded in a composite of cotton fibres, the physical and mechanical properties of this high-quality composite material satisfy all of the current requirements for various industrial applications, depending on the type of pad.

Very good insulation properties ensure optimum spring deflection and level consistency under both static and dynamic loads.

CHARACTERISTICS AND FACTS

- Effective structure-borne noise insulation
- Ageing resistance: Virtually unlimited service life with adherence to load values. High degree of levelling constancy.
- Temperature resistance: -20° C to +80° C
- Chemical resistance: Excellent resistance to most commercially available coolants and lubricants, fuels and cleaning agents
- Vibration insulation properties: Very high degree

NOTES

- Bilz insulation pads, anti-slip and spacer pads can be cut to size with any circular or band saw.
- We are happy to supply special sizes on request.
- The specified maximum load is composed of the static and dynamic load of the machine.
- The optimum insulation effect is achieved at approx. 80-90 % of the specified maximum load.
- Selected insulation pads can also be supplied with a profile on one side (description e.g. B4-1).
- The specified coefficient of friction refers to standard industrial screed.
- Cutting tolerance is according to DIN 7715/T5, class P3.
- **W:** Waffle structure designs for compensation of uneven floors (B32W, B30W, B13W)

The insulation pad type B13W is also available as a pad set, e.g. for insulating foundations, see also page 13.

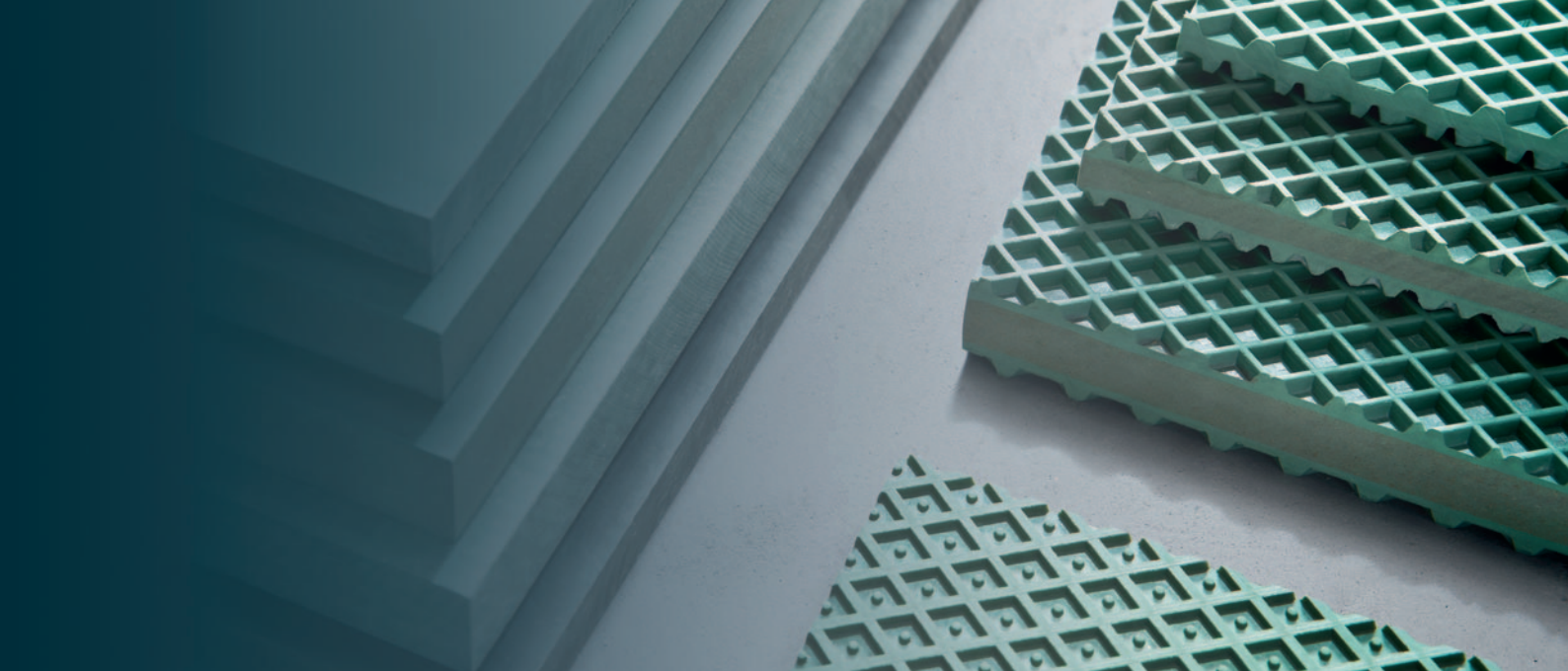

FOUR POSSIBLE OPTIONS FOR THE USE OF INSULATION PADS FOR MACHINE INSTALLATION

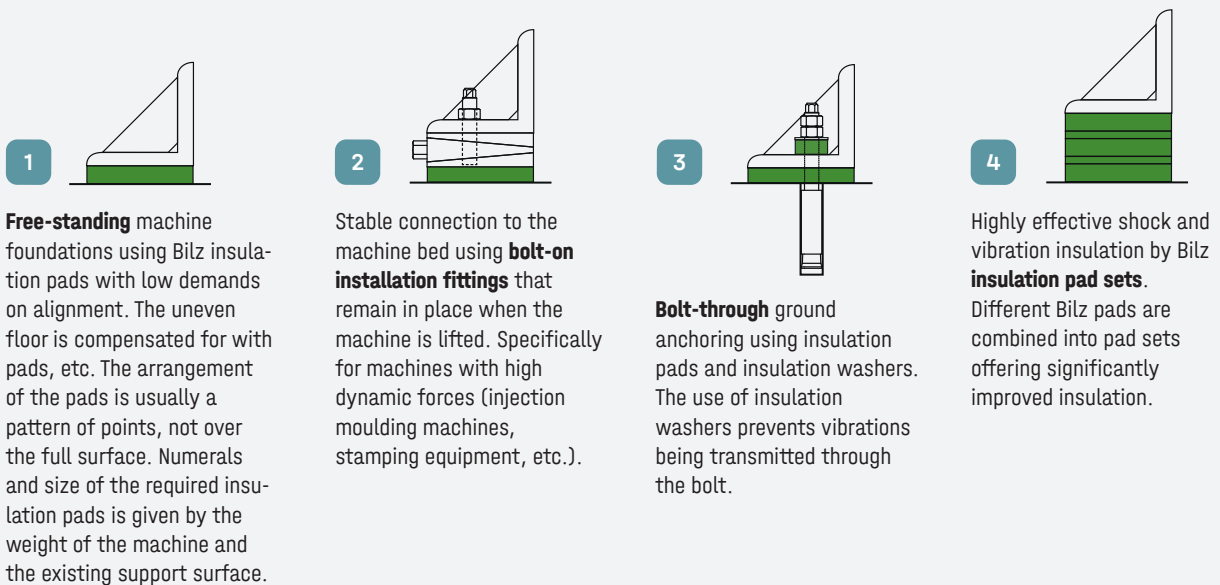

Schematic representation of the application of insulation pads and pad sets

BILZ INSULATION PADS ARE RESISTANT TO MOST COMMERCIALY AVAILABLE SUBSTANCES

- Lubricants:
Greases for rolling and plain bearings, gear greases
- Synthetic lubricants:
Polyalkylene glycols, carboxylic acid esters, radiator antifreeze
- Cleaning agents:
Chlorinated hydrocarbons, petroleum ether, cold cleaners
- Cleaning agents (aqueous solutions):
Detergents and rinsing agents, wetting agents, diluted acids, diluted alkalis, salt solutions
- Fuels and combustibles:
Petrol, diesel fuel, heating oil, aviation fuel, special fuels
- Flame retardant liquids:
Oil-in-water emulsions, water-in-oil emulsions, aqueous polymer solutions
- Mineral oils:
Common water-miscible cooling lubricants, ATF (Automatic Transmission Fluid), cooling lubricants, water-miscible corrosion protection oils, slideway oils, compressed air oils, lubricating oils, heat transfer oils, filter oils, rolling oils, automotive gear oils, mineral oil-based brake fluids

ARTICLE NUMBERS AND STANDARD SIZES



- Available square standard formats
- Special and intermediate formats are manufactured individually on request

SQUARE	B6	B0	B4	B50	B5	B32	B32W	B30	B30W	B13W	BS1	BS	BN	BR7	B8
mm															
1000 × 500	01-0323	01-0005	01-0202	01-0291	01-0260	01-0139	01-0175	01-0057	01-0087	01-0038	01-0462	01-0441	01-0371	01-0391	01-0350
500 × 500	01-0342	01-0027	01-0223	01-0310	01-0280	01-0158	01-0194	01-0079	01-0106	01-0051	01-0473	01-0458	01-0384	01-0406	01-0365
500 × 250	01-0341	01-0026	01-0222	01-0309	01-0279	01-0157	01-0193	01-0078	01-0105	01-0050	01-0472	01-0457	01-0383	01-0405	01-0364
250 × 250	01-0337	01-0020	01-0217	01-0305	01-0274	01-0153	01-0189	01-0072	01-0101	01-0048	01-0470	01-0453	01-0380	01-0402	01-0361
250 × 150	01-0336	01-0019	01-0216	01-0304	01-0273	01-0152	01-0188	01-0071	01-0100	01-0047	01-0469	01-0452	01-0379	01-0401	01-0360
200 × 200	01-0334	01-0016	01-0214	01-0302	01-0271	01-0150	01-0186	01-0069	01-0098	01-0046	01-0468	01-0450	01-0378	01-0400	01-0359
200 × 100	01-0333	01-0015	01-0213	01-0301	01-0270	01-0149	01-0185	01-0068	01-0097	01-0045	01-0467	01-0449	01-0377	01-0399	01-0358
150 × 150	01-0330	01-0012	01-0210	01-0298	01-0267	01-0146	01-0182	01-0065	01-0094	01-0043	01-0465	01-0446	01-0375	01-0397	01-0356
150 × 100	01-0329	01-0011	01-0209	01-0297	01-0266	01-0145	01-0181	01-0064	01-0093	01-0042	01-0464	01-0445	01-0374	01-0396	01-0355
150 × 75	01-0331	01-0013	01-0211	01-0299	01-0268	01-0147	01-0183	01-0066	01-0095	01-0044	01-0466	01-0447	01-0376	01-0398	01-0357
100 × 100	01-0324	01-0006	01-0204	01-0292	01-0261	01-0140	01-0176	01-0058	01-0088	01-0039	01-0463	01-0442	01-0372	01-0392	01-0351
100 × 50	01-0325	01-0007	01-0205	01-0293	01-0262	01-0141	01-0177	01-0060	01-0089	01-0040	-	-	01-0373	01-0393	01-0352
75 × 75	01-0346	01-0034	01-0228	01-0313	01-0284	01-0162	01-0198	01-0083	01-0110	01-0053	-	-	01-0388	01-0409	01-0369
50 × 50	01-0343	01-0029	01-0224	01-0311	01-0281	01-0159	01-0195	01-0080	01-0107	01-0052	-	-	01-0385	01-0407	01-0366

ROUND



Ø / 300 mm



Ø 238 mm



Ø 200 mm



Ø 150 mm



Ø 110 mm



Ø 75 mm



Ø 50 mm

● Available round standard formats

ROUND	B6	B0	B4	B50	B5	B32	B32W	B30	B30W	B13W	BS1	BS	BN	BR7	B8
Ø mm															
50	01-0339	01-0024	01-0220	01-0307	01-0277	01-0155	01-0191	01-0076	01-0103						
75	01-0345	01-0033	01-0227	01-0312	01-0283	01-0161	01-0197	01-0082	01-0109						
110	01-0326	01-0008	01-0206	01-0294	01-0263	01-0142	01-0178	01-0061	01-0090						
150	01-0328	01-0010	01-0208	01-0296	01-0265	01-0144	01-0180	01-0063	01-0092	These pad types are available on request.					
200	01-0332	01-0014	01-0212	01-0300	01-0269	01-0148	01-0184	01-0067	01-0096						
238	01-0335	01-0018	01-0215	01-0303	01-0272	01-0151	01-0187	01-0070	01-0099						
300	01-0338	01-0021	01-0218	01-0306	01-0275	01-0154	01-0190	01-0073	01-0102						

SELECTION OF SUITABLE PAD TYPE

USE	B6	B0	B4	B50/B5	B32/B32W	B30/B30W	B13W
Metal processing							
Processing centre	●	●					
Drilling machine			●				
Boring mills	●						
Lathe		●					
Lathe, long bed	●						
Milling machine		●	●				
Press					●	●	
Saw			●				
Impact shears					●	●	
Grinding machine	●	●					
Punching machine/nibbler					●	●	●
Transfer line	●						
Plastic processing							
Granulating machine		●	●				
Milling and hammering machine					●	●	
Injection moulding machine			●	●			●
Printing and paper industry							
Bookbinding/printing machine, folder			●				
Scissors, packaging line			●		●		
Measuring and checks							
Measuring machines, scales, microscopes							●
Pad set							
Foundation							●

PAD TYPE B6

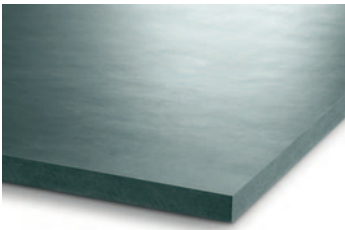

Extremely heavy-duty insulation pad with the highest level of constancy. For very heavy and long-bed machines.

Type	Loads N/cm ²	Thickness mm	Friction- coeff.
B6	50-350	15	0,6

DYNAMIC NATURAL FREQUENCY

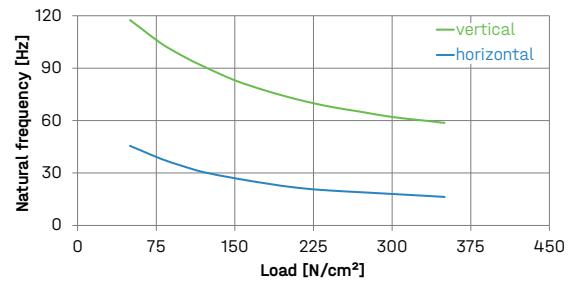

PAD TYPE B0

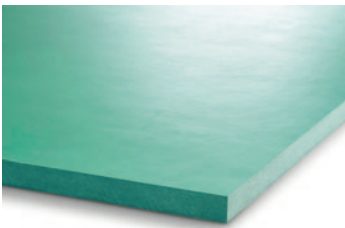

Insulation pad with high level consistency, specifically for machines with low intrinsic rigidity such as processing centres, lathes and grinding machines, etc.

Type	Loads N/cm ²	Thickness mm	Friction- coeff.
B0	50-200	15	0,6

DYNAMIC NATURAL FREQUENCY

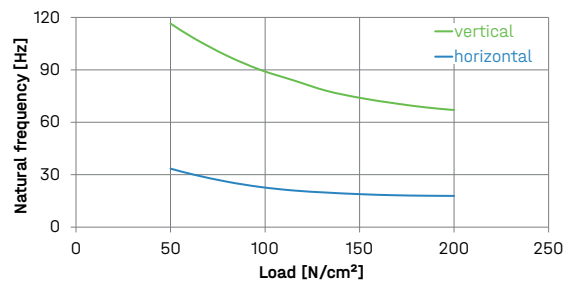

PAD TYPE B4

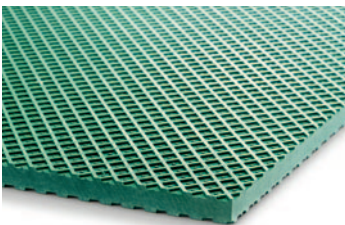

Universally applicable insulation pad for machine tools, plastic and printing machines. Very well suited for machines that tend to "wander". Also available profiled on one side (B4-1).

Type	Loads N/cm ²	Thickness mm	Friction- coeff.
B4	30-100	15	0,8

DYNAMIC NATURAL FREQUENCY

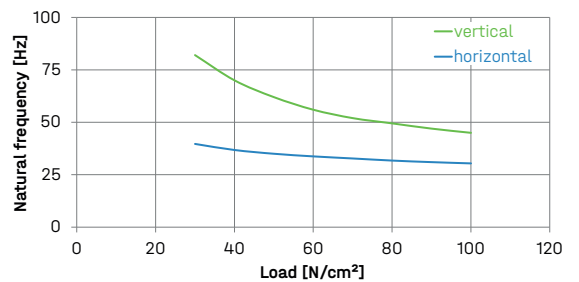

PAD TYPE B50

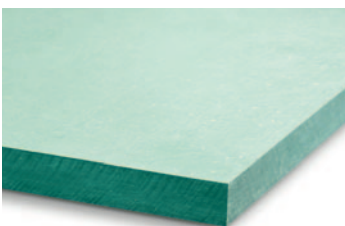

Insulation pad for machines having high machine dynamics and only a small contact surface, e.g. presses, punches, shears etc.

Type	Loads N/cm ²	Thickness mm	Friction- coeff.
B50	50-200	25	0,8

DYNAMIC NATURAL FREQUENCY

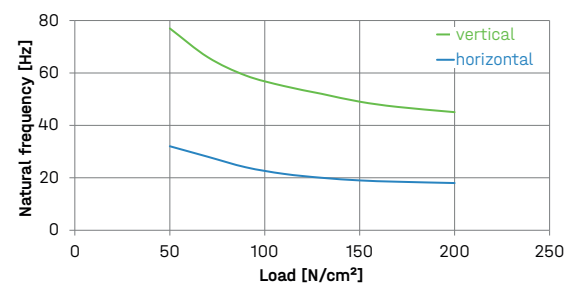

PAD TYPE B5

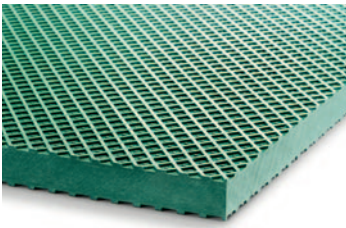

Profiled insulation pad to compensate for uneven floors. Designed specifically for machines with only a small contact surface and high dynamics, e.g. presses, punches, shears etc.

Type	Loads N/cm ²	Thickness mm	Friction- coeff.
B5	50-160	25	0,8

DYNAMIC NATURAL FREQUENCY

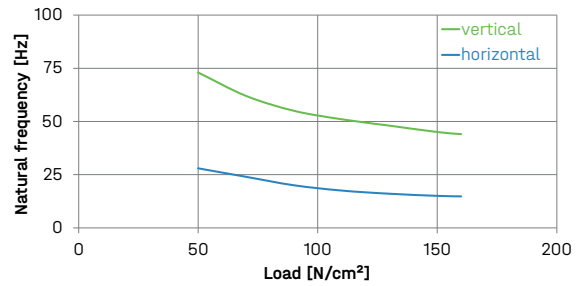

PAD TYPE B32

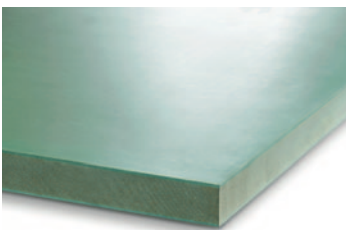

Soft insulation pad without profile with excellent insulation effect, designed specifically for machines with low dynamics such as medium presses, punches etc.

Type	Loads N/cm ²	Thickness mm	Friction- coeff.
B32	20-80	25	0,8

DYNAMIC NATURAL FREQUENCY

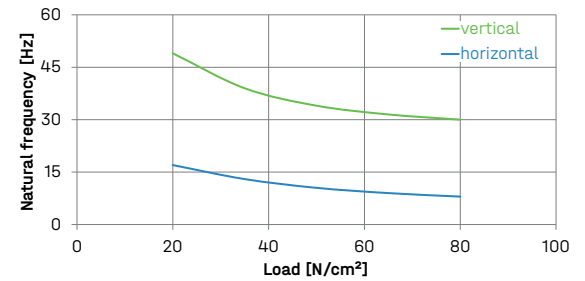

PAD TYPE B32 W

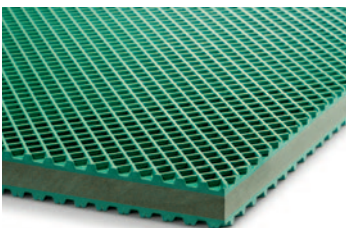

Very soft insulation pad with profile and very high insulation effect. Suitable for machines with low dynamics.

Type	Loads N/cm ²	Thickness mm	Friction- coeff.
B32W	35-70	25	0,8

DYNAMIC NATURAL FREQUENCY

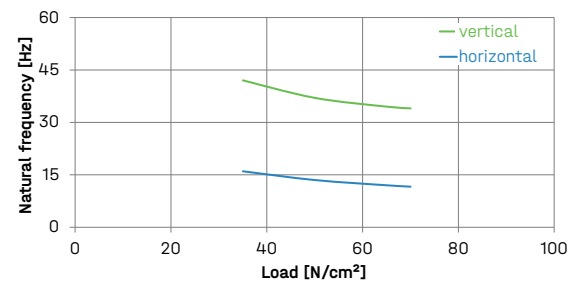

PAD TYPE B30

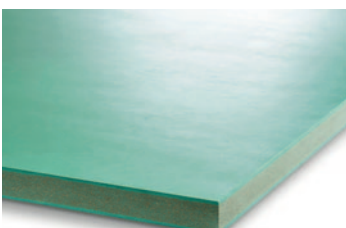

Soft insulation pad without profile, designed specifically for effective insulation when installed on upper floors.

Type	Loads N/cm ²	Thickness mm	Friction- coeff.
B30	20-80	18	0,8

DYNAMIC NATURAL FREQUENCY

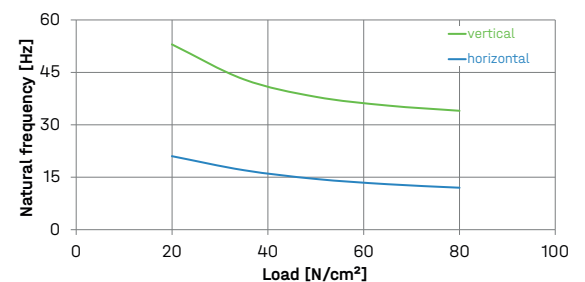

PAD TYPE B30W

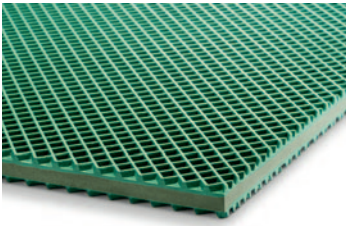

Very soft, profiled insulation pad for static applications with optimum insulating effect due to low-frequency absorption, e.g. for measuring and testing machines, scales, microscopes. B30W also available profiled on one side: B30W-1

Type	Loads N/cm ²	Thickness mm	Friction- coeff.
B30W	5-40	18	0,8

PAD TYPE B13W

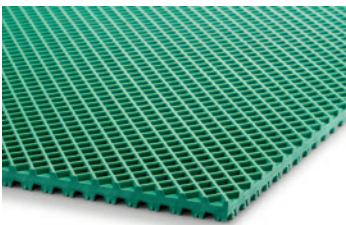

Profiled insulation pad for highest insulation values, can be layered up to 6 times, tuning up to approx. 25 Hz (up to approx. 8 Hz if insulation pad set), best as pad set for foundation insulation.

Type	Loads N/cm ²	Thickness mm	Friction- coeff.
B13W	5-40	13	0,8

ANTI-SLIP PADS

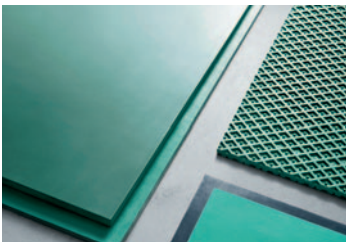

Bilz anti-slip and distance pads, for mechanical levelling and anti-slip. Not used for vibration insulation.

BR7 also available profiled on one side: BR7-1

Type	Loads N/cm ²	Thickness mm	Friction- coeff.
BS1	10-400	1	0,9
BS	10-400	2	0,9
BN	10-300	5	0,6
BR7	10-160	7	0,8
B8	5-40	8	0,8

DYNAMIC NATURAL FREQUENCY

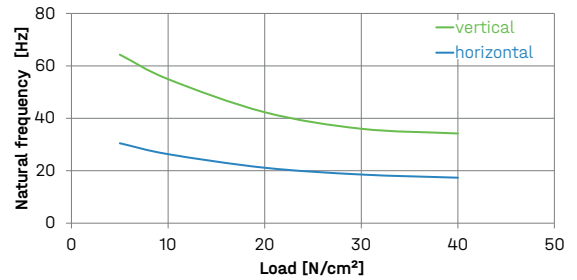

DYNAMIC NATURAL FREQUENCY

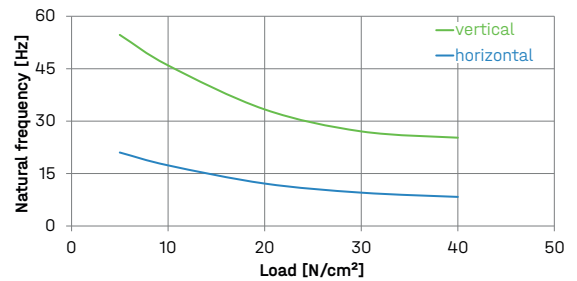

PAD TYPE BS1



PAD TYPE BS

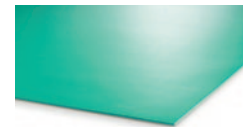

PAD TYPE BN



PAD TYPE BR7

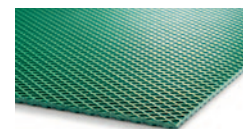

PAD TYPE B8



PAD SETS

By multiple layering of 2-6 Bilz insulation pads to form pad sets, reduced natural frequencies can be achieved and thus the insulating effect can be significantly increased compared to single-layer insulation pads.

These pad sets are ideal for **large machines and swing foundations**. Even after years of dynamic stress, the vibration-damping and insulation properties of the insulation pad sets remain unchanged.

STANDARD SIZES

Standard Item no. 01-0476
Special sizes Item no. 01-0475

Please specify the desired size when ordering.

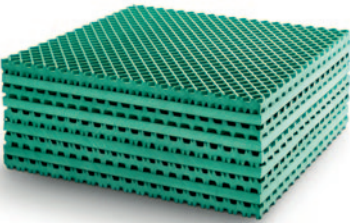

The permissible weight load of a pad set is between 5 and 40N/cm² depending on the application.

The number and dimensions of the insulation layers as well as the required distribution of the pad sets is determined by Bilz specifically for the application.

We are happy to supply special sizes on request.

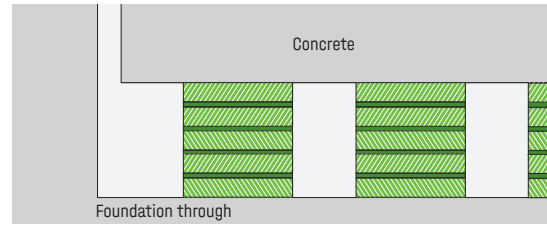

Format: Pad sets under a foundation (concrete block)

SQUARE

	Length mm				
	500	250	200	166	150
Width mm					
500	●	●			
250	●	●	●	●	
200		●	●	●	
166		●	●	●	
150					●

NATURAL FREQUENCY

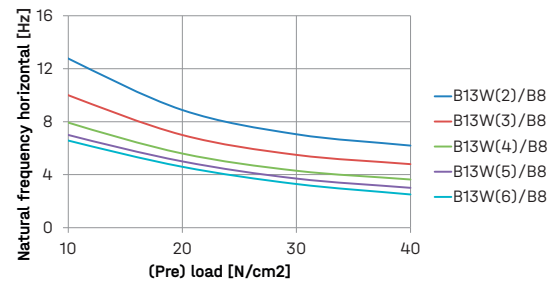
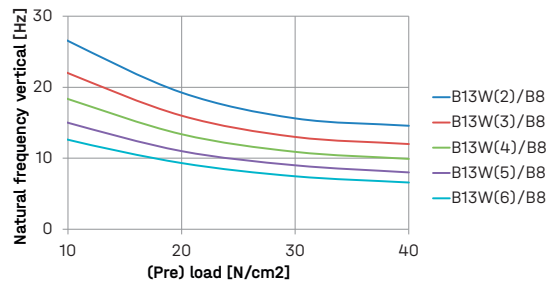

Type	Thickness unloaded mm	Natural vertical frequency Hz	Natural horizontal frequency Hz
B13W/B8, 2x	34	14,5 - 26,5	5,5 - 12,5
B13W/B8, 3x	55	12,0 - 22,0	4,5 - 10,0
B13W/B8, 4x	76	10,0 - 18,5	3,5 - 8,0
B13W/B8, 5x	97	8,0 - 15,0	3,0 - 7,0
B13W/B8, 6x	118	6,5 - 12,5	2,5 - 6,5

LEVELLING ELEMENTS

THE COST-EFFECTIVE COMBINATION OF PRECISE LEVELLING ADJUSTMENT AND EFFECTIVE INSULATION FROM DISRUPTIVE VIBRATIONS IN MACHINE INSTALLATIONS



All information about our levelling elements is also available on our website.

Bilz levelling elements are used for vibration and structure-borne noise insulated machine installation.

The maintenance-free machine feet ensure simple and precise levelling of machines and are available in many versions.

The appropriate size and insulation pads are selected according to the application and load. The levelling range can be adjusted depending on the selected bolt length and according to individual requirements (except for BNSH / BNSHA).

NOTES

- The specified maximum load is composed of the static and dynamic load of the machine. The optimum insulation effect is achieved at approx. 80-90 % of the specified maximum load.
- You will find the specified insulation pad type in the type designation: BNSH 80/50 is equipped with insulation pad B50, BNSHA 120/32 with B32 etc.
- Permissible temperature range: -20 °C to +80 °C
- Details on the characteristics of the insulation pads used can be found on pp.10-12.
- Tables for the selection of available bolts can be found on pp. 20-21. Nuts and washers are included. Please specify the size when ordering.
- Please contact us, if the suitable dimension, colour, pad fitting or bolt connection required for your application is not listed. We also have numerous special solutions available besides our standard solutions and colours. We are always happy to offer our advice.

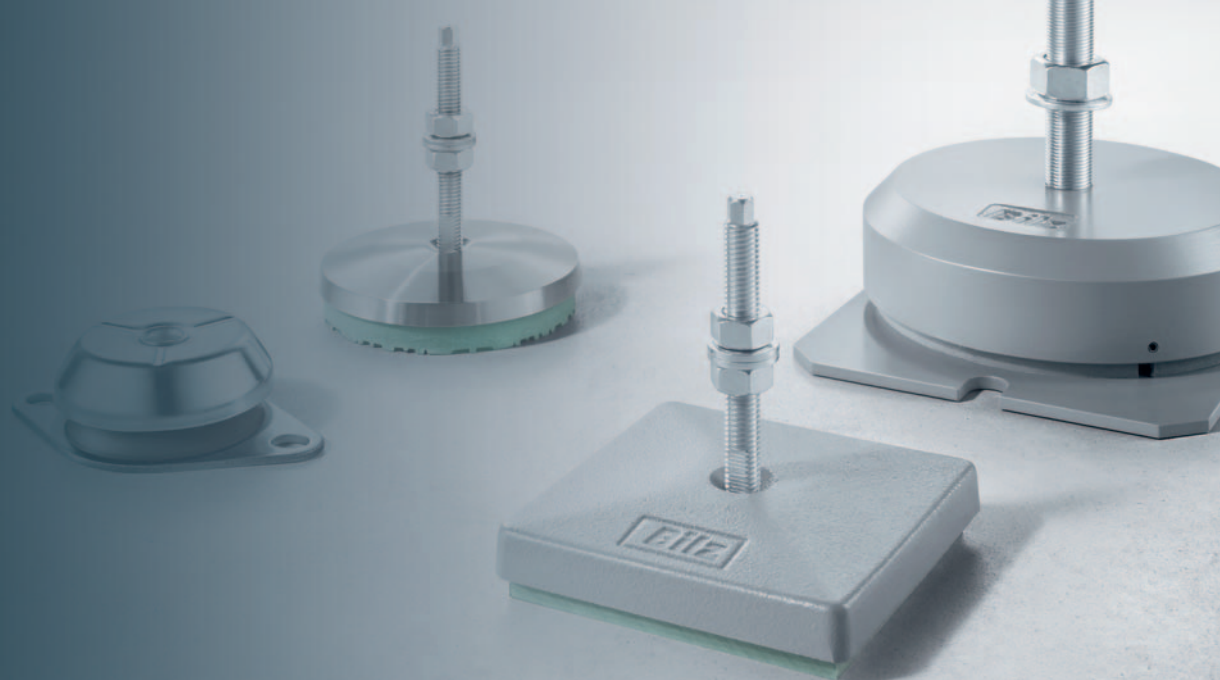

SERIES BNSH | BNSHA

Round levelling element, specifically for high demands on horizontal stability, e.g. injection moulding machines, presses, punches.

BNSH: without bolt-on floor mounting | **BNSHA:** with bolt-on floor mounting

- Specially developed levelling element for the bearing of injection moulding machines, presses, punches, etc.
- Optimum load distribution due to the proven pressure pad design.
- Very high horizontal stability over the entire levelling range.
- The BNSHA levelling element with bolt-on floor mounting is particularly suitable for all machines that tend to 'wander'.
- The floor mounting is not designed as a safeguard against tipping.

Colour: RAL 7037, dusty grey

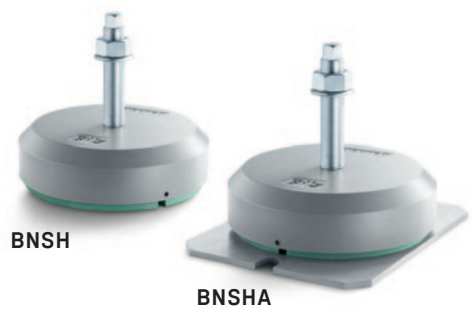

BNSH | BNSHA

Type BNSH / BNSHA	Item no. BNSH	Item no. BNSHA	max. load N/Stk.	H BNSH mm	H BNSHA mm	Ø D mm	Adjustment range mm	Fine thread G	Pitch
70/0	12-0042	12-0016	5.000	31	36	80	+6	M10	1,25
80/50	12-0047	12-0020	9.500	43	48	96	+18	M12	1,5
120/50	12-0024	12-0003	20.000	51	56	133	+18	M16	1,5
160/50	12-0028	12-0006	40.000	52	57	175	+17	M20	1,5
175/50	12-0032	12-0009	45.000	56	64	193	+17	M20	1,5
200/50	12-0036	12-0012	65.000	63	71	229	+16	M24	2,0
250/50	12-0040	12-0015	90.000	67	75	270	+15	M30	2,0
70/30	12-0043	12-0017	2.400	34	39	80	+6	M10	1,25
80/32	12-0045	12-0018	4.800	43	48	96	+18	M12	1,5
120/32	12-0022	12-0001	9.600	51	56	133	+18	M16	1,5
160/32	12-0026	12-0004	17.000	52	57	175	+17	M20	1,5
175/32	12-0030	12-0007	20.800	56	64	193	+17	M20	1,5
200/32	12-0034	12-0010	29.000	63	71	229	+16	M24	2,0
250/32	12-0038	12-0013	41.000	67	75	270	+15	M30	2,0

Properties of the insulation pad:

B50:

- Good insulating effect when machines are installed on natural ground.
- Very well suited for machines with high dynamic forces.

B32:

- Very good insulating effect.
- Specially developed for use on upper floors or on insufficiently stable ground.

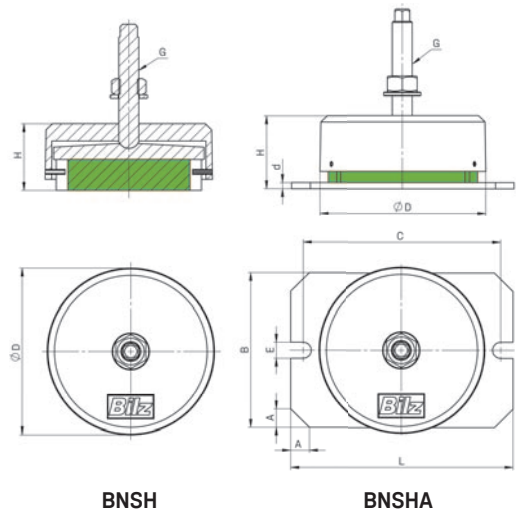

BNSHA DIMENSIONS FLOOR PAD

Type	L mm	A mm	B mm	C mm	E mm	d mm
BNSHA 70	125	15	75	105	8	5
BNSHA 80	140	15	90	120	8	5
BNSHA 120	180	15	125	160	13	5
BNSHA 160	220	15	170	200	16	5
BNSHA 175	260	20	185	230	20	8
BNSHA 200	300	20	225	270	20	8
BNSHA 250	330	20	265	300	20	8

SERIES BNV | BNVS

Square levelling element with compensation of angular differences by means of movable levelling bolt.
BNV: optionally with movable levelling bolt | **BNVS:** connected with movable levelling bolt

- Proven and highly effective pad elements, preferably for light to medium-heavy machines with corresponding locating holes or threads in the machine base.
- The BNVS element is used wherever a rigid connection between element and machine is required.
- The movable levelling bolt can compensate for any unevenness of the floor or angular differences of up to $\pm 3^\circ$.

Colour: RAL 7037, dusty grey

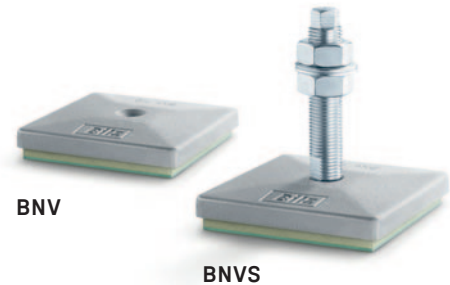

BNV | BNVS

Type BNV / BNVS	Item no. BNV	Item no. BNVS	max. load N/Stk.	L mm	B mm	H mm
50/4	08-0030	10-0013	2.000	60	60	22
80/4	08-0034	10-0023	4.700	85	85	24
110/4	08-0004	10-0004	12.000	123	123	28
115/4	08-0008	10-0026	11.400	163	88	29
150/4	08-0016	10-0009	18.000	147	147	32
200/4	08-0020	10-0025	37.000	264	165	44
50/0	08-0028	10-0011	4.000	60	60	22
80/0	08-0032	10-0021	9.500	85	85	24
110/0	08-0002	10-0002	24.000	123	123	28
115/0	08-0006	10-0027	22.800	163	88	29
150/0	08-0014	10-0007	36.000	147	147	32
200/0	08-0018	10-0028	74.000	264	165	44
50/30W	08-0029	10-0012	950	60	60	25
80/30W	08-0033	10-0022	2.300	85	85	27
110/30W	08-0003	10-0003	5.000	123	123	31
115/30W	08-0007	10-0029	4.500	163	88	32
150/30W	08-0015	10-0008	7.300	147	147	35
200/30W	08-0019	10-0030	15.000	264	165	47

Properties of the insulation pad:

B4:

- Medium-hard insulation pad with good vibration and structure-borne sound insulation.
- Suitable for universal use.

B0:

- Insulation pad without profile and with high level consistency, e.g. for lathes, processing centres, etc.

B30W:

- Soft tuning for very good insulating effect, e.g. for grinding machines, testing equipment, measuring machines, etc.

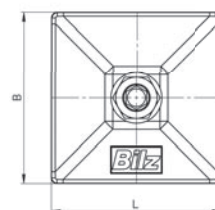
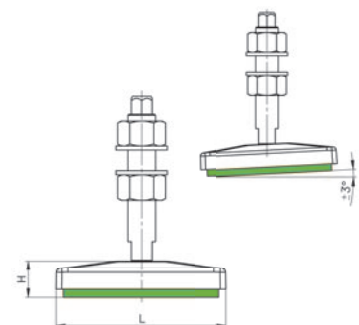

BNVS

SERIES BNR | BNRS

Round levelling element with compensation of angular differences by means of movable levelling bolt.
BNR: optionally with movable levelling bolt | **BNRS:** connected with movable levelling bolt

- Proven and highly effective pad elements, preferably for light to medium-heavy machines with corresponding locating holes or threads in the machine base.
- The BNRS element is used wherever a rigid connection between element and machine is required.
- The movable levelling bolt can compensate for any unevenness of the floor or angular differences of up to $\pm 3^\circ$.

Colour: RAL 7037, dusty grey



BNR | BNRS

Type BNR / BNRS	Item no. BNR	Item no. BNRS	max. load N/Stk.	Ø D mm	H mm
50/4	09-0035	11-0014	1.700	60	21
70/4	09-0048	11-0019	3.600	79	29
80/4	09-0045	11-0023	4.200	85	23
110/4	09-0006	11-0004	9.100	120	31
150/4	09-0016	11-0009	17.000	162	34,5
200/4	09-0025	11-0026	31.000	213	42
50/0	09-0033	11-0012	3.400	60	21
70/0	09-0049	11-0017	7.200	79	29
80/0	09-0042	11-0024	8.400	85	23
110/0	09-0002	11-0002	18.200	120	31
150/0	09-0012	11-0007	34.000	162	34,5
200/0	09-0021	11-0027	62.000	213	42
50/30W	09-0034	11-0013	700	60	24
70/30W	09-0050	11-0018	1.400	79	32
80/30W	09-0043	11-0025	1.600	85	26
110/30W	09-0003	11-0003	3.500	120	34
150/30W	09-0013	11-0008	6.900	162	34,5
200/30W	09-0022	11-0028	12.000	213	42

Properties of the insulation pad:

B4:

- Medium-hard insulation pad with good vibration and structure-borne sound insulation.
- Suitable for universal use.

B0:

- Insulation pad without profile and with high level consistency, e.g. for lathes, processing centres, etc.

B30W:

- Soft tuning for very good insulating effect, e.g. for grinding machines, testing equipment, measuring machines, etc.

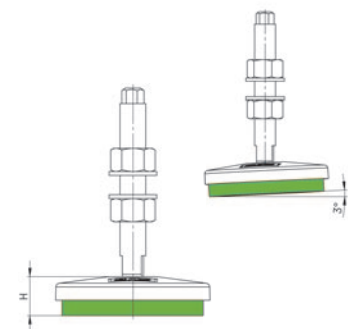

BNRS

SERIES BNRV | BNRSV

Round, stainless steel levelling element with compensation of angular differences by means of movable levelling bolt. Specially designed for applications in the food, pharmaceutical and clean room industries.

BNRV: optionally with movable levelling bolt | BNRSV: connected with movable levelling bolt

- For machines with corresponding locating holes or threads in the machine feet used in the food, luxury food, packaging, chemical and pharmaceutical industries, as well as for clean room applications.
- BNRSV elements are used wherever a rigid connection between element and machine is required.
- The movable levelling bolt can compensate for any unevenness of the floor or angular differences of up to $\pm 3^\circ$.

Colour: Stainless steel



BNRV

BNRSV

BNRV | BNRSV

Type BNRV / BNRSV	Item no. BNRV	Item no. BNRSV	max. load N/Stk.	Ø D mm	H mm
50/4	30-0031	30-0014	1.700	54	24
70/4	30-0035	30-0018	3.600	76	25
110/4	30-0023	30-0007	9.100	116	27,5
150/4	30-0027	30-0011	17.000	156	29,5
50/30W	30-0030	30-0013	700	54	27
70/30W	30-0034	30-0017	1.400	76	28
110/30W	30-0022	30-0006	3.500	116	30,5
150/30W	30-0026	30-0010	6.900	156	32,5
50/BR7	30-0032	30-0016	2.800	54	16
70/BR7	30-0036	30-0020	5.800	76	17
110/BR7	30-0024	30-0009	14.500	116	19,5
150/BR7	30-0028	30-0012	27.500	156	21,5

Properties of the insulation pad:

B4:

- Medium-hard insulation pad with good vibration and structure-borne sound insulation.
- Suitable for universal use.

B30W:

- Soft tuning for very good insulating effect, e.g. for grinding machines, testing equipment, measuring machines, etc.

BR-7:

- Anti-slip pad without vibration insulation.

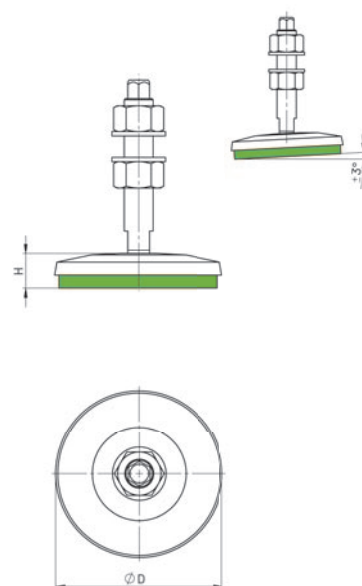

SERIES BFE

Cost-effective round, stainless steel levelling element with compensation of angular differences by means of movable levelling bolt. Specially designed for applications in the food, pharmaceutical and clean room industries.

BFE: round, stainless steel version, with flexible levelling bolt

- Cost-effective stainless steel design for machines with corresponding locating holes or threads in the machine feet in the food, packaging, chemical and pharmaceutical industries.
- The movable levelling bolt can compensate for any unevenness of the floor or angular differences of up to $\pm 7.5^\circ$.
- BFE levelling elements cannot be used in combination with Bilz insulation pads.

Colour: Stainless steel



Isolierplatte: NBR70

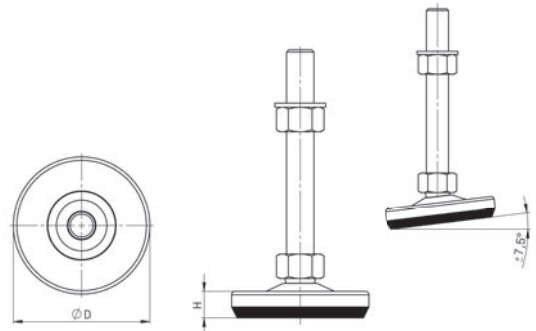

BFE

Type BFE	Item no. BFE	max. load N/Stk.	Ø D mm	H mm
50	30-0003	3.000	50	14
80	30-0004	8.500	80	17
100	30-0001	20.000	100	19
125	30-0002	30.000	125	19

SERIES GMA

Cost-effective rubber-metal element, designed specifically for robust vibration and structure-borne noise insulation of machines and aggregates in outdoor areas.

GMA: Bolt-on rubber-metal parts

- Stationary and mobile use of machines, equipment and aggregates, e.g. engines, machine tools, woodworking machines, screens, rolling mills, pumps, compressors, air conditioning and ventilation systems.
- Natural frequency approx. 25 Hz
- These elements are supplied without bolts.

Colour: Galvanised steel

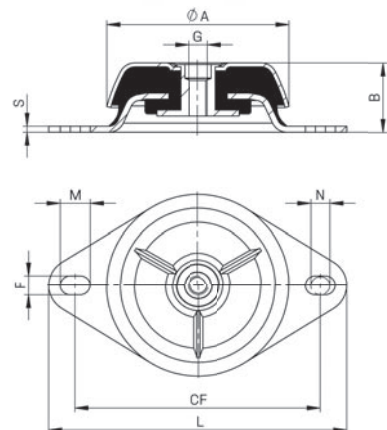

GMA

Type GMA	Item no.	Ø A mm	B mm	F mm	M mm	N mm	CF mm	L mm	S mm	max. Pressure load N/Stk.	max. Springing mm	Thread G
83	13-0009	83	36	11,5	15	15	110	135	3	2.300	3,5±1,5	M10
92	13-0010	92	34	10	15	10	123	150	3	3.000	5,0±1,5	M10
106	13-0011	106	41	13	19	19	143	169	4	4.200	3,5±1,5	M12
150	13-0012	150	54	14	18	18	182	218	4	10.000	3,5±1,5	M16

SERIES BNL

Cost-effective levelling element for machines with high vertical and horizontal dynamic forces.
 BNL: Steel, with levelling bolt

- Sufficient insulation from vibrations and structure-borne sound.
- Precise levelling pressure pad for optimum weight distribution.
- The rubber element is resistant to commercial acids, alkalis and lubricating oils.
- Matching levelling bolts, each with a nut and washer, are included.
- Cannot be used in combination with Bilz insulation pads.

Colour: Galvanised steel



BNL

Type BNL	Item no. BNL	max. load N/Stk.	Ø D mm	Ø E mm	H mm	Adjustment range A	G	GL mm
80	14-0027	5.000	80	60	45	+12	M12 × 1,5	86
120	14-0028	11.000	120	60	45	+15	M16 × 1,5	80
160	14-0029	21.000	160	70	56	+20	M20 × 1,5	125
200	14-0030	40.000	200	70	68	+20	M20 × 1,5	122

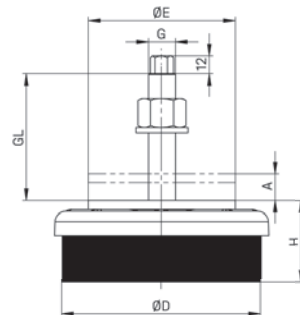

ACCESSORIES

A large range of different bolts are available for each type of levelling element. You will find the appropriate bolts in the following tables. The bolt type must be selected according to the static and dynamic load in the application. We are happy to help you with this.

LEVELLING AND FIXING BOLTS

BNSH | BNSHA

Thread	Pitch	Material	Length 80 mm	Length 100 mm	Length 125 mm	Length 150 mm	Length 200 mm
M10	1,25	verzinkt	19-0282	19-0283	19-0284		
M12	1,5	verzinkt	19-0039	19-0032	19-0034	19-0036	
M16	1,5	verzinkt		19-0076	19-0261	19-0081	19-0083
M20	1,5	verzinkt		19-0156	19-0162	19-0167	19-0172
M24	2,0	verzinkt				19-0219	19-0221
M30	2,0	verzinkt				19-0242	19-0245

The galvanised levelling and fastening bolts for the elements mentioned on the left are included and are supplied with one nut and one washer each. Please specify the size when ordering.

BNV | BNVS BNR | BNRS BNRV | BNRSV

Thread	Material	Length 70 mm	Length 100 mm	Length 125 mm	Length 150 mm	Length 200 mm	Length 250 mm	Length 300 mm
M10	verzinkt	19-0025	19-0020					
	Edelstahl	18-0012	18-0006					
M12	verzinkt		19-0042	19-0045	19-0048			
	Edelstahl		18-0017	18-0068	18-0020			
M16	verzinkt		19-0086	19-0092	19-0095	19-0099	19-0102	
	Edelstahl		18-0031	18-0061	18-0034	18-0037	18-0056	
M18	verzinkt		19-0131	19-0134	19-0137	19-0140	19-0143	
M20	verzinkt		19-0179	19-0183	19-0186	19-0189	19-0192	
	Edelstahl		18-0042	18-0063	18-0045	18-0048		
M24	verzinkt				19-0215	19-0224	19-0227	19-0230
	Edelstahl				18-0053	18-0064	18-0065	

The levelling and fixing bolts for the elements mentioned on the left have a standard thread and are supplied incl. 2 nuts and washers each. Please specify the size when ordering.

BNV | BNVS:
galvanised or stainless steel

BNR | BNRS:
galvanised or stainless steel

BNRV | BNRSV:
Stainless steel

ALLOCATION OF LEVELLING BOLT SIZE TO LEVELLING ELEMENT SIZE

BNRS

Thread	BNRS 50	BNRS 70	BNRS 80	BNRS 110	BNRS 150	BNRS 200
M10	●					
M12	●	●	●			
M16		●	●	●	●	
M18			●	●	●	●
M20				●	●	●
M24					●	●

We recommend the combinations marked with a dot.

BNVS

Thread	BNVS 50	BNVS 80	BNVS 110	BNVS 115	BNVS 150	BNVS 200
M10	●					
M12	●	●	●			
M16		●	●	●	●	
M18			●	●	●	●
M20				●	●	●
M24					●	●

BNRSV

Thread	BNRSV 50	BNRSV 70	BNRSV 110	BNRSV 150
M10	●			
M12	●	●	●	
M16		●	●	●
M18			●	●
M20				●
M24				●

STAINLESS STEEL BOLTS

BFE

Thread	Length 50 mm	Length 80 mm	Length 100 mm	Length 120 mm	Length 150 mm	Length 180 mm	Length 200 mm	Length 250 mm	Length 300 mm
M8	18-0213	18-0214	18-0215	18-0216	18-0217	18-0218	18-0219		
M10	18-0220	18-0221	18-0222	18-0223	18-0224	18-0225	18-0226		
M12	18-0227	18-0228	18-0229	18-0230	18-0231	18-0232	18-0233		
M16	18-0234	18-0235	18-0236	18-0237	18-0238	18-0239	18-0240	18-0241	18-0242
M20	18-0243	18-0244	18-0245	18-0246	18-0247	18-0248	18-0249	18-0250	18-0251
M24	18-0252	18-0253	18-0254	18-0255	18-0256	18-0257	18-0258	18-0259	18-0260
M30	18-0261	18-0262	18-0263	18-0264	18-0265	18-0266	18-0267	18-0268	18-0269

The stainless steel bolts for the elements mentioned on the left have a standard thread and are suitable for all element sizes. They are supplied with 2 nuts and washers each and are available in numerous combinations.

PRECISION LEVELLING WEDGES

BILZ PRECISION LEVELLING WEDGES ARE MACHINE WEDGES FOR HIGHLY PRECISE LEVELLING WHEN INSTALLING AND STORING MACHINES, ESPECIALLY WITH HIGH LOADS



All information about our precision levelling wedges is also available on our website.

Due to their large contact area Bilz precision levelling wedges for vibration and structure-borne noise insulation offer optimum support and stiffening of the machine bed.

They are available in a wide range of sizes and dimensions as free-standing, bolt-on to the machine or bolt-through to the foundation design.

NOTES

Effective vibration insulation also at very high loads

The proven design principle enables the machine to be quickly levelled to a degree of levelling in the 1/100mm range even at loads of 100 tons per wedge. The powerful self-locking effect of the levelling bolt prevents self-adjustment under the effects of vibration.

Depending on the application, their use in conjunction with Bilz insulation pads creates the perfect strength coherence and very effective vibration insulation.

- You will find the insulation pad type used in the type designation, e.g. PKA 3-0 is equipped with isolation pad B0, PKA 5-4 with isolation pad B4.
- We would be happy to provide special solutions with regard to painting, insulation pad configuration and dimensions on request.
- The specified maximum load is composed of the static and dynamic load of the machine. The optimum insulation effect is achieved at approx. 80-90 % of the specified maximum load.
- Permissible temperature range: -20 °C to +80 °C
- The general tolerances according to ISO 2768 vL apply to the length and width specifications.
- The height specifications in the centre position are subject to a tolerance of ± 1 mm.

Please contact us if the appropriate insulation pad configuration for your application is not listed. We are also able to develop a wide range of special solutions. We are always happy to offer our advice.



SPANNER SIZES FOR BILZ PRECISION LEVELLING WEDGES

Type	Inside	Outside
PK 1	SW 6	SW 13
PK 2	SW 10	SW 19
PK 2.5	SW 10	SW 19
PK 3	SW 12	SW 22
PK 3.2	SW 12	SW 22
PK 3.5	SW 12	SW 22
PK 3.8	SW 12	SW 22
PK 4	SW 14	SW 27
PK 4.5	SW 14	SW 27
PK 5	SW 14	SW 27
PK 5.5	SW 14	SW 27
PK 6	SW 14	SW 27
PK 7	SW 17	SW 32
PK 8	SW 19	SW 41
PK 9	SW 22	SW 50

Type	Inside	Outside
PKA / PKD 1	SW 10	SW 19
PKA / PKD 2	SW 12	SW 22
PKA / PKD 3	SW 14	SW 27
PKA / PKD 4	SW 14	SW 27
PKA / PKD 5	SW 14	SW 27
PKA / PKD 6	SW 17	SW 32
PKA / PKD 7	SW 19	SW 41
PKA / PKD 8	SW 22	SW 50

Type	Outside
PKA / PKD 1-AL	SW 19
PKA / PKD 2-AL	SW 22
PKA / PKD 3-AL	SW 27
PKA / PKD 4-AL	SW 27

Type	Outside
PKAK / PKDK 1-AL	SW 19
PKAL / PKDK 2-AL	SW 22
PKAK / PKDK 3-AL	SW 27
PKAL / PKDK 4-AL	SW 27

SERIES PK

Free-standing precision levelling wedges especially for machines without mounting holes in the machine bed.

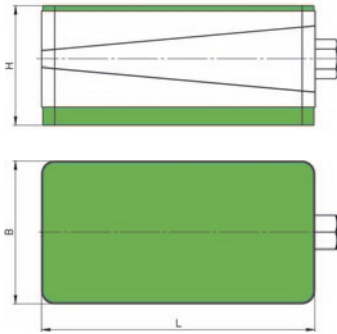

Description

- PK - free-standing precision levelling wedge
- Especially for machines without mounting holes in the machine bed
- Suitable levelling wedges are also available for existing installations
- **Colour:** RAL 7037, dusty grey

Please contact us if the appropriate insulation pad configuration for your application is not listed. We are also able to develop a wide range of special solutions. We are always happy to offer our advice.

A-MOUNTING



- Universally usable for machine tools and injection moulding machines.
- Especially for machines with high horizontal forces.
- Very high sliding prevention performance.

Upper side: Anti-slip pad BR7-1

Underside: Insulation pad B4-1

Type PK A-mounting	Item no.	max. load N/Stk.	L mm	B mm	H centre position mm	Adjustment range mm
PK 1-A	02-0004	5.400	105	55	59	+4/-5
PK 2-A	02-0011	10.000	150	75	63	+5/-6
PK 2.5-A	02-0104	12.000	115	115	67	+4/-5
PK 3-A	02-0025	18.000	200	95	67	+5/-5
PK 3/72-A	02-0019	18.000	200	95	94	+5/-4
PK 3.2-A	02-0110	20.000	150	150	68	+5/-6
PK 3.5-A	02-0116	26.000	115	250	92	+4/-8
PK 3.8-A	02-0122	26.000	170	170	76	+6/-8
PK 4-A	02-0042	38.000	200	200	70	+5/-7
PK 4/72-A	02-0033	38.000	200	200	94	+5/-7
PK 4.5-A	02-0128	39.000	180	230	84	+9/-9
PK 5-A	02-0050	48.000	200	250	94	+10/-7
PK 5.5-A	02-0134	73.000	300	250	106	+10/-8
PK 6-A	02-0057	80.000	250	330	94	+7/-10
PK 7-A	02-0064	117.500	300	400	95	+8/-12
PK 8-A	02-0071	195.500	400	500	95	+8/-14
PK 9-A	02-0078	294.500	500	600	137	+12/-15

B-MOUNTING



- Special design for CNC lathes, grinding machines, boring and milling machines, processing centres, transfer lines.

Upper side: Anti-slip pad BS

Underside: Insulation pad B0

Typ PK B-mounting	Item no.	max. load N/Stk.	L mm	B mm	H centre position mm	Adjustment range mm
PK 1-B	02-0005	10.000	105	55	54	+4/-5
PK 2-B	02-0012	21.000	150	75	58	+5/-6
PK 2.5-B	02-0105	25.000	115	115	62	+4/-5
PK 3-B	02-0026	36.000	200	95	62	+5/-5
PK 3/72-B	02-0020	36.000	200	95	89	+5/-4
PK 3.2-B	02-0111	43.000	150	150	63	+5/-6
PK 3.5-B	02-0117	55.000	115	250	87	+4/-8
PK 3.8-B	02-0123	55.000	170	170	71	+6/-8
PK 4-B	02-0043	77.000	200	200	65	+5/-7
PK 4/72-B	02-0034	77.000	200	200	89	+5/-7
PK4.5-B	02-0129	79.500	180	230	79	+9/-9
PK 5-B	02-0051	97.000	200	250	89	+10/-7
PK 5.5-B	02-0135	144.000	300	250	101	+10/-8
PK 6-B	02-0058	161.000	250	330	89	+7/-10
PK 7-B	02-0065	236.000	300	400	90	+8/-12
PK 8-B	02-0072	393.000	400	500	90	+8/-14
PK 9-B	02-0079	591.000	500	600	132	+12/-15

C-MOUNTING



- Highly effective vibration insulation.
- Especially suitable for use on upper floors.

Upper side: Anti-slip pad BS
Underside: Insulation pad B32

Typ PK C-mounting	Item no.	max. load N/Stk.	L mm	B mm	H centre position mm	Adjustment range mm
PK 1-C	02-0006	4.600	105	55	64	+4/-5
PK 2-C	02-0013	8.700	150	75	68	+5/-6
PK 2.5-C	02-0106	10.000	115	115	72	+4/-5
PK 3-C	02-0027	14.600	200	95	72	+5/-5
PK 3/72-C	02-0021	14.600	200	95	99	+5/-4
PK 3.2-C	02-0112	17.000	150	150	73	+5/-6
PK 3.5-C	02-0118	22.000	115	250	97	+4/-8
PK 3.8-C	02-0124	22.000	170	170	81	+6/-8
PK 4-C	02-0044	31.000	200	200	75	+5/-7
PK 4/72-C	02-0035	31.000	200	200	99	+5/-7
PK 4.5-C	02-0133	32.000	180	230	89	+9/-9
PK 5-C	02-0052	38.900	200	250	99	+10/-7
PK 5.5-C	02-0136	58.000	300	250	111	+10/-8
PK 6-C	02-0059	64.500	250	330	99	+7/-10
PK 7-C	02-0066	94.500	300	400	100	+8/-12
PK 8-C	02-0073	167.000	400	500	100	+8/-14
PK 9-C	02-0080	236.000	500	600	142	+12/-15

D-MOUNTING

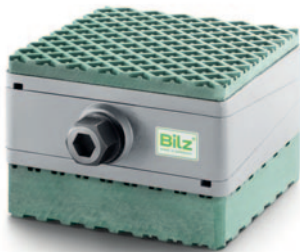

- For machines with extremely high dynamic forces, such as presses, punches, shears.

Upper side: Anti-slip pad BR7-1
Underside: Insulation pad B5

Typ PK D-mounting	Item no.	max. load N/Stk.	L mm	B mm	H centre position mm	Adjustment range mm
PK 1-D	02-0007	8.700	105	55	69	+4/-5
PK 2-D	02-0014	17.000	150	75	73	+5/-6
PK 2.5-D	02-0107	20.000	115	115	77	+4/-5
PK 3-D	02-0028	29.000	200	95	77	+5/-5
PK 3/72-D	02-0022	29.000	200	95	104	+5/-4
PK 3.2-D	02-0113	34.500	150	150	78	+5/-6
PK 3.5-D	02-0119	44.500	115	250	102	+4/-8
PK 3.8-D	02-0125	44.500	170	170	86	+6/-8
PK 4-D	02-0045	62.000	200	200	80	+5/-7
PK 4/72-D	02-0036	62.000	200	200	104	+5/-7
PK 4.5-D	02-0130	64.000	180	230	94	+9/-9
PK 5-D	02-0053	77.000	200	250	104	+10/-7
PK 5.5-D	02-0137	116.000	300	250	116	+10/-8
PK 6-D	02-0060	129.000	250	330	104	+7/-10
PK 7-D	02-0067	189.000	300	400	105	+8/-12
PK 8-D	02-0074	314.000	400	500	105	+8/-14
PK 9-D	02-0081	470.000	500	600	147	+12/-15

SERIES PK

Free-standing precision levelling wedges especially for machines without mounting holes in the machine bed.

E-MOUNTING



- For machines and systems where vibration insulation is not required.
- Good frictional connection due to anti-slip pads.
- Very low overall height.

Upper side: Anti-slip pad BS

Underside: Anti-slip pad BS

Typ PK E-mounting	Item no.	max. load N/Stk.	L mm	B mm	H centre position mm	Adjustment range mm
PK 1-E	02-0008	16.000	105	55	41	+4/-5
PK 2-E	02-0015	32.500	150	75	45	+5/-6
PK 2.5-E	02-0108	38.000	115	115	49	+4/-5
PK 3-E	02-0029	54.900	200	95	49	+5/-5
PK 3/72-E	02-0023	54.900	200	95	76	+5/-4
PK 3.2-E	02-0114	65.000	150	150	50	+5/-6
PK 3.5-E	02-0120	83.500	115	250	74	+4/-8
PK 3.8-E	02-0126	83.500	170	170	58	+6/-8
PK 4-E	02-0046	116.400	200	200	52	+5/-7
PK 4/72-E	02-0037	116.400	200	200	76	+5/-7
PK 4.5-E	02-0131	120.000	180	230	66	+9/-9
PK 5-E	02-0054	145.500	200	250	76	+10/-7
PK 5.5-E	02-0138	218.000	300	250	88	+10/-8
PK 6-E	02-0061	242.000	250	330	76	+7/-10
PK 7-E	02-0068	355.000	300	400	77	+8/-12
PK 8-E	02-0075	589.500	400	500	77	+8/-14
PK 9-E	02-0082	887.000	500	600	119	+12/-15

F-MOUNTING



- For extremely high loads.
- Very high levelling constancy.

Upper side: Anti-slip pad BS

Underside: Insulation pad B6

Typ PK F-mounting	Item no.	max. load N/Stk.	L mm	B mm	H centre position mm	Adjustment range mm
PK 1-F	02-0009	19.000	105	55	54	+4/-5
PK 2-F	02-0016	38.000	150	75	58	+5/-6
PK 2.5-F	02-0109	44.500	115	115	62	+4/-5
PK 3-F	02-0030	64.000	200	95	62	+5/-5
PK 3/72-F	02-0024	64.000	200	95	89	+5/-4
PK 3.2-F	02-0115	75.800	150	150	63	+5/-6
PK 3.5-F	02-0121	97.000	115	250	87	+4/-8
PK 3.8-F	02-0127	97.000	170	170	71	+6/-8
PK 4-F	02-0047	135.000	200	200	65	+5/-7
PK 4/72-F	02-0039	135.000	200	200	89	+5/-7
PK 4.5-F	02-0132	139.500	180	230	79	+9/-9
PK 5-F	02-0055	170.000	200	250	89	+10/-7
PK 5.5-F	02-0139	253.000	300	250	101	+10/-8
PK 6-F	02-0062	282.000	250	330	89	+7/-10
PK 7-F	02-0069	414.000	300	400	90	+8/-12
PK 8-F	02-0076	680.000	400	500	90	+8/-14
PK 9-F	02-0083	1.035.000	500	600	132	+12/-15

SERIES PKA

Bolt-on precision levelling wedges for machines with strong forces that require a firm connection to the machine bed.

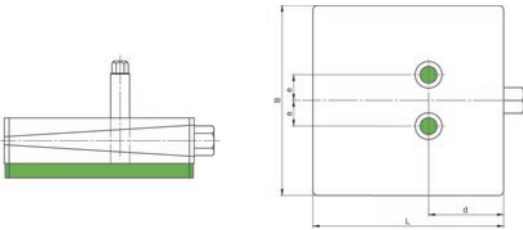

Description

- Bolt-on Bilz precision levelling wedge PKA are used for machines with large forces that require a solid connection to the machine bed, e.g. injection moulding machines, impact machines, cold extrusion presses, etc.
- The bolt-on machine feet remain in position even when the machine is lifted, significantly easing the installation of the machine.
- **Colour:** RAL 7037, dusty grey.
- **Fixing bolts:** Tables for the selection of available bolts can be found on p. 33.

BO-MOUNTING



- Suitable for lathes, boring mills, grinding machines and processing centres.

Underside: Insulation pad B0

Type PKA BO mounting	Item no.	max. load N/Stk.	L mm	B mm	H centre position mm	d mm	e mm	Internal thread	Adjustment range mm
PKA 1-0	03-0007	25.000	115	115	60	50	24	M16	+3/-3
PKA 2-0	03-0010	43.000	150	150	61	58	23	M18	+4/-4
PKA 3-0	03-0024	77.000	200	200	63	76	27	M20	+4/-6
PKA 3/72-0	03-0020	77.000	200	200	87	76	27	M20	+4/-7
PKA 4-0	03-0028	97.000	200	250	87	95	27	M20	+10/-7
PKA 5-0	03-0033	161.000	250	330	87	125	105	M24	+6/-10
PKA 6-0	03-0037	236.000	300	400	88	150	95	M24	+8/-12
PKA 7-0	03-0040	393.000	400	500	88	200	130	M24	+8/-14
PKA 8-0	03-0043	591.000	500	600	130	255	150	M30 x 2	+12/-15

B4-MOUNTING



- Suitable for plastic injection moulding machines, die casting machines, planers, impact machines, cold extrusion presses etc.
- Extreme slip resistance.

Underside: Insulation pad B4

Typ PKA B4 mounting	Item no.	max. load N/Stk.	L mm	B mm	H centre position mm	d mm	e mm	Internal thread	Adjustment range mm
PKA 1-4	03-0008	12.000	115	115	60	50	24	M16	+3/-3
PKA 2-4	03-0011	20.000	150	150	61	58	23	M18	+4/-4
PKA 3-4	03-0025	38.000	200	200	63	76	27	M20	+4/-6
PKA 3/72-4	03-0021	38.000	200	200	87	76	27	M20	+4/-7
PKA 4-4	03-0030	48.000	200	250	87	95	27	M20	+10/-7
PKA 5-4	03-0034	80.000	250	330	87	125	105	M24	+6/-10
PKA 6-4	03-0038	117.500	300	400	88	150	95	M24	+8/-12
PKA 7-4	03-0041	195.500	400	500	88	200	130	M24	+8/-14
PKA 8-4	03-0044	294.500	500	600	130	255	150	M30 x 2	+12/-15

SERIES PKD

Used for machines that need to be anchored to the floor due to unfavourable centre of gravity conditions and low inherent rigidity.

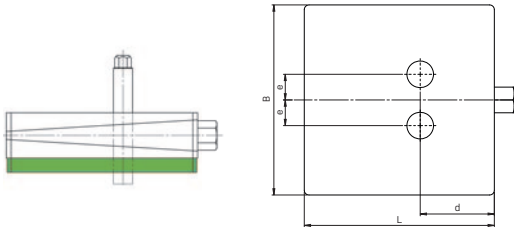

Description

- Bolt-through Bilz precision levelling wedges PKD are used for machines where anchoring is essential due to unfavourable centre of gravity conditions.
- They can also be used for machines that have to be pushed or pulled when levelling - i.e. for machines with low intrinsic rigidity. Suitable for plastic injection moulding machines, die casting machines, planers, impact machines, cold extrusion presses etc.
- Extreme slip resistance.
- **Colour:** RAL 7037, dusty grey.
- **Fixing bolts:** Tables for the selection of available bolts can be found on p. 33.
- The delivery includes a suitable insulating washer for insulating the bolt head.

BO-MOUNTING



- Suitable for boring and milling machines, processing centres, special machines, long lathes, long planers.

Underside: Insulation pad B0

Typ PKD BO mounting	Item no.	max. load N/Stk.	L mm	B mm	H centre position mm	d mm	e mm	Drill hole mm	Adjustment range mm
PKD 1-0	04-0003	25.000	115	115	60	50	24	22	+4/-5
PKD 2-0	04-0005	43.000	150	150	61	58	23	23	+5/-6
PKD 3-0	04-0009	77.000	200	200	63	76	27	26	+3/-7
PKD 3/72-0	04-0007	77.000	200	200	87	76	27	26	+4/-7
PKD 4-0	04-0011	97.000	200	250	87	95	27	26	+10/-7
PKD 5-0	04-0013	161.000	250	330	87	125	105	30	+6/-10
PKD 6-0	04-0015	236.000	300	400	88	150	95	30	+8/-12
PKD 7-0	04-0017	393.000	400	500	88	200	130	35	+8/-14
PKD 8-0	04-0019	591.000	500	600	130	255	150	35	+12/-15

SERIES PKAK | PKDK

Can be bolted to the machine bed (PKAK) / bolt-through (PKDK) with calotte and used to compensate for angle differences, especially for machines with high geometric requirements.

PKAK

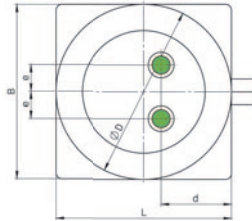
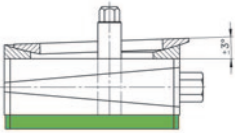

PKDK

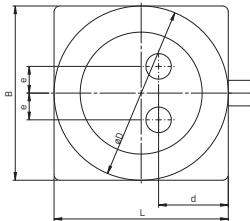
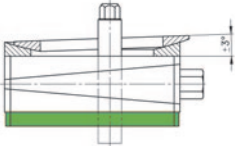

Description

- Bilz precision levelling wedges **PKAK (bolt-on) / PKDK (bolt-through)** with spherical cap to compensate for angular differences between machines and foundations, e.g. in the case of unprocessed machine supports or uneven floors.
- For machines with a long bed and high geometric requirements.
- PKAK: The bolt-on levelling wedges remain in position even when the machine is lifted, significantly easing the installation of the machine
- **Colour:** RAL 7037, dusty grey.
- **Fixing bolts:** Tables for the selection of available bolts can be found on p. 33.
- PKDK: The delivery includes a suitable insulating washer for insulating the bolt head.

BO-MOUNTING



- With calotte
- Especially suitable for injection moulding machines, impact machines, cold extrusion presses.

Upper side: lacquered

Underside: Insulation pad B0

Typ PKAK BO mounting	Item no.	max. load N/Stk.	L mm	B mm	H centre position mm	ØD mm	d mm	e mm	Internal thread	Adjustment range mm
PKAK 1-0	05-0003	25.000	115	115	70	110	50	24	M16	+3/-3
PKAK 2-0	05-0008	43.000	150	150	77	150	58	23	M18	+4/-4
PKAK 3-0	05-0011	77.000	200	200	79	150	76	27	M20	+4/-6
PKAK 4-0	05-0015	97.000	200	250	103	150	95	27	M20	+10/-7

Typ PKDK BO mounting									Drill hole mm	
PKDK 1-0	06-0003	25.000	115	115	70	110	50	24	22	+4/-5
PKDK 2-0	06-0006	43.000	150	150	77	150	58	23	23	+5/-6
PKDK 3-0	06-0008	77.000	200	200	79	150	76	27	26	+3/-7
PKDK 4-0	06-0010	97.000	200	250	103	150	95	27	26	+10/-7

SERIES PKA-AL | PKD-AL

Easily adjustable levelling wedge with excellent wear properties, particularly suitable for EMC and clean room applications, can be bolted to the machine bed (PKA-AL) or anchored to the floor (PKD-AL).

PKA-AL

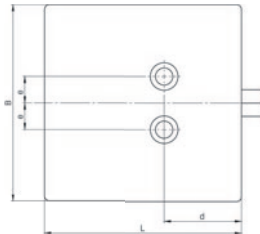
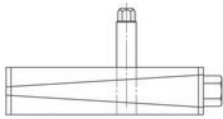

PKD-AL

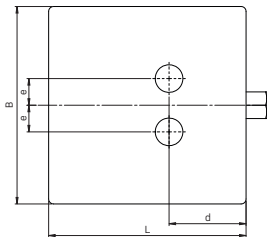
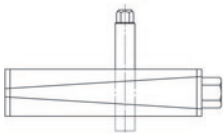

Description

- Bilz precision levelling wedges **PKA-AL (bolt-on) / PKD-AL (bolt-through)** in aluminium version with hard anodising (hardcoat) are characterised by a high layer density, high hardness - up to 600 HV - and very good wear protection properties. The levelling wedge is very easy to adjust and particularly suitable for EMC applications.
- PKA-AL: The bolt-on machine feet remain in position even when the machine is lifted, significantly easing the installation of the machine.
- Can be fitted with Bilz insulation pads (also in EPDM for clean room applications).
- We supply special lubricants for applications in clean rooms.
- General tolerances according to ISO 2768 mK.
- **Colour:** Intrinsic colouring dark grey.
- **Fixing bolts:** Tables for the selection of available bolts can be found on p. 33.

VARIANTS

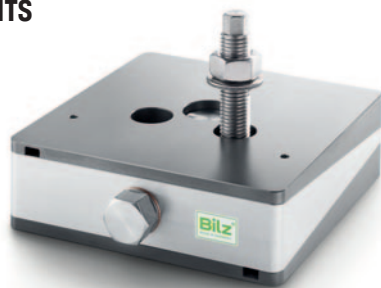

- Especially suitable for machines in the food and luxury food industry, packaging, chemical and pharmaceutical industry as well as for EMC and clean room applications.
- Easily adjustable, with very good wear properties.

Type	Item no.	max. load N/Stk.	L mm	B mm	H centre position mm	d mm	e mm	Internal thread	Adjustment range mm
PKA 1-AL	03-0060	19.000	115	115	44	50	24	M16	+3/-3
PKA 2-AL	03-0061	32.000	150	150	47	60	24	M18	+3/-5
PKA 3-AL	03-0062	57.000	200	200	53	80	27	M20	+4/-5
PKA 4-AL	03-0063	72.000	200	250	73	95	27	M20	+9/-5

Type	Item no.	max. load N/Stk.	L mm	B mm	H centre position mm	d mm	e mm	Drill hole mm	Adjustment range mm
PKD 1-AL	04-0020	19.000	115	115	44	50	24	22	+3/-3
PKD 2-AL	04-0021	32.000	150	150	47	60	24	22	+3/-5
PKD 3-AL	04-0022	57.000	200	200	53	80	27	26	+4/-5
PKD 4-AL	04-0023	72.000	200	250	73	95	27	26	+9/-5

SERIES PKAK-AL | PKDK-AL

Easily adjustable levelling wedge with excellent wear properties, particularly suitable for EMC and clean room applications, can be bolted to the machine bed (PKAK-AL) or anchored to the floor (PKDK-AL), and to balance out angular differences

PKAK-AL

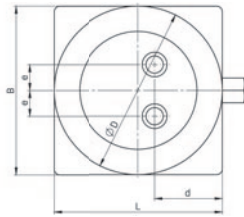
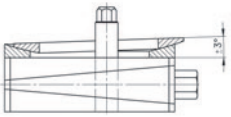

PKDK-AL

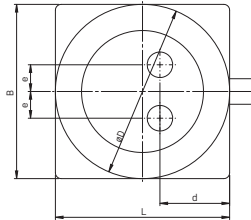
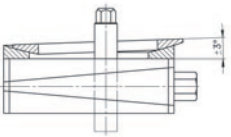

Description

- Bilz precision levelling wedges **PKAK-AL (bolt-on) / PKDK-AL (bolt-through)** in aluminium version with hard anodising (hardcoat) are notable for their high layer density, hardness - up to 600 HV, and excellent wear protection properties. The levelling wedge is very easy to adjust and particularly suitable for EMC applications.
- With calotte to balance out angular differences
- PKAK-AL: The bolt-on machine feet remain in position even when the machine is lifted, significantly easing the installation of the machine.
- Can be fitted with Bilz insulation pads (also in EPDM for clean room applications).
- We supply special lubricants for applications in clean rooms.
- General tolerances according to ISO 2768 mK.
- **Colour:** Intrinsic colouring dark grey.
- **Fixing bolts:** Tables for the selection of available bolts can be found on p. 33.

VARIANTS



- With calotte
- Especially suitable for machines in the food and luxury food industry, packaging, chemical and pharmaceutical industry as well as for EMC and clean room applications.
- Easily adjustable, with very good wear properties.

Type	Item no.	max. load	L	B	H centre position	ØD	d	e	Internal thread	Adjustment range
PKAK-AL		N/Stk.	mm	mm	mm	mm	mm	mm		mm
PKAK 1-AL	05-0018	19.000	115	115	54	110	50	24	M16	+3/-3
PKAK 2-AL	05-0019	32.000	150	150	63	150	60	24	M18	+3/-5
PKAK 3-AL	05-0020	57.000	200	200	69	150	80	27	M20	+4/-5
PKAK 4-AL	05-0021	72.000	200	250	89	150	95	27	M20	+9/-5

Type									Drill hole	
PKDK-AL									mm	
PKDK 1-AL	06-0012	19.000	115	115	54	110	50	24	22	+3/-3
PKDK 2-AL	06-0013	32.000	150	150	63	150	60	24	22	+3/-5
PKDK 3-AL	06-0014	57.000	200	200	69	150	80	27	26	+4/-5
PKDK 4-AL	06-0015	72.000	200	250	89	150	95	27	26	+9/-5

ACCESSORIES

Our accessories complete the performance requirements of our precision levelling wedges and consequently support an ideal machine arrangement.

INSULATING PADS



Structure-borne sound insulation of firmly anchored machines and pipe suspensions.

FOR BOLT HEAD INSULATION

Our insulation washers for bolt heads provide sufficient vibration and structure-borne noise insulation of fixed machines and components. They can be used at temperatures from -20 °C to +80 °C and are highly resistant to industrially used oils, greases, acids and cooling mixtures.

WALL PLUGS



Fischer heavy duty wall plug SL
SL Fischer reaction anchor R and threaded rod RG
Fischer anchor bolt FAZ

FOR FLOOR ANCHORING

Fischer anchors are part of our product range. Other models and manufacturers on request.

EXTENSION



Easy and quick alignment of the machine in confined spaces.

FOR LEVELLING WEDGE BOLT

If the levelling bolt is difficult to access, we recommend using the levelling bolt extension. This ensures quick and easy levelling even when space is limited. These levelling aids are available in different lengths and wrench widths depending on the levelling wedge shoe used. Please contact us for further details.

FIXING BOLTS

Suitable bolts and nuts with standard thread can be supplied on request. The delivery includes 1 nut and 1 washer each.

ARTICLE NUMBERS FOR BOLTS AND NUTS

PKA | PKAK

Thread	Material	Length 100 mm	Length 125 mm	Length 150 mm	Length 200 mm
M16	verzinkt	19-0323	19-0324		
	Edelstahl	18-0083	18-0080		
M18	verzinkt	19-0325	19-0357	19-0441	
	Edelstahl	18-0084			
M20	verzinkt	19-0326		19-0327	19-0308
	Edelstahl	18-0085		18-0081	
M24	verzinkt			19-0329	
	Edelstahl			18-0082	
M30×2	verzinkt			19-0242	19-0245



PKD | PKDK

Thread	Material	Length 150 mm	Length 200 mm	Length 250 mm	Length 300 mm
M16	verzinkt	19-0094	19-0098	19-0101	
	Edelstahl	18-0033	18-0036	18-0202	
M18	verzinkt	19-0136	19-0139	19-0142	
M20	verzinkt	19-0185	19-0188	19-0191	
	Edelstahl	18-0044	18-0047		
M24	verzinkt	19-0214	19-0223	19-0226	19-0229
	Edelstahl	18-0052	18-0069	18-0203	18-0204

PKA-AL | PKAK-AL

Thread	Material	Length 100 mm	Length 125 mm	Length 150 mm
M16	Edelstahl	18-0083	18-0080	
M18	Edelstahl	18-0084		
M20	Edelstahl	18-0085		18-0081

PKD-AL | PKDK-AL

Thread	Material	Length 150 mm	Length 200 mm	Length 250 mm	Length 300 mm
M16	Edelstahl	18-0033	18-0036	18-0202	
M20	Edelstahl	18-0044	18-0047		
M24	Edelstahl	18-0052	18-0069	18-0203	18-0204

HORIZONTAL ELEMENTS

FOR MACHINES WITH HIGH HORIZONTAL FORCES OR FOR LATERAL LINKING AND FIXING.



All information about our horizontal elements is also available on our website.

Bilz horizontal elements are used for machines with extremely strong horizontal forces or when machines are linked and have to be fixed laterally.

HORIZONTAL ELEMENT

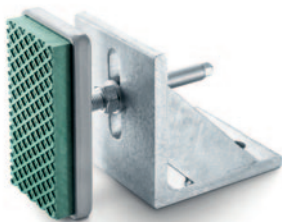

Size 1:
Steel angle, levelling element
model BNVS 115/5, 3 bolts
M16 × 150, 2 plugs M16

Size 2:
Steel angle, levelling element
model BNVS 115/5, 4 bolts
M20 × 150, 3 plugs M20

FOR LATERAL FIXATION

For machines with extremely strong horizontal forces or when machines are linked and have to be fixed laterally.

Bilz levelling elements model BNV are used as a pressure pad, which ensures vibration insulation.

Bilz horizontal elements are available in 2 sizes with 16,500 N pressure absorption.

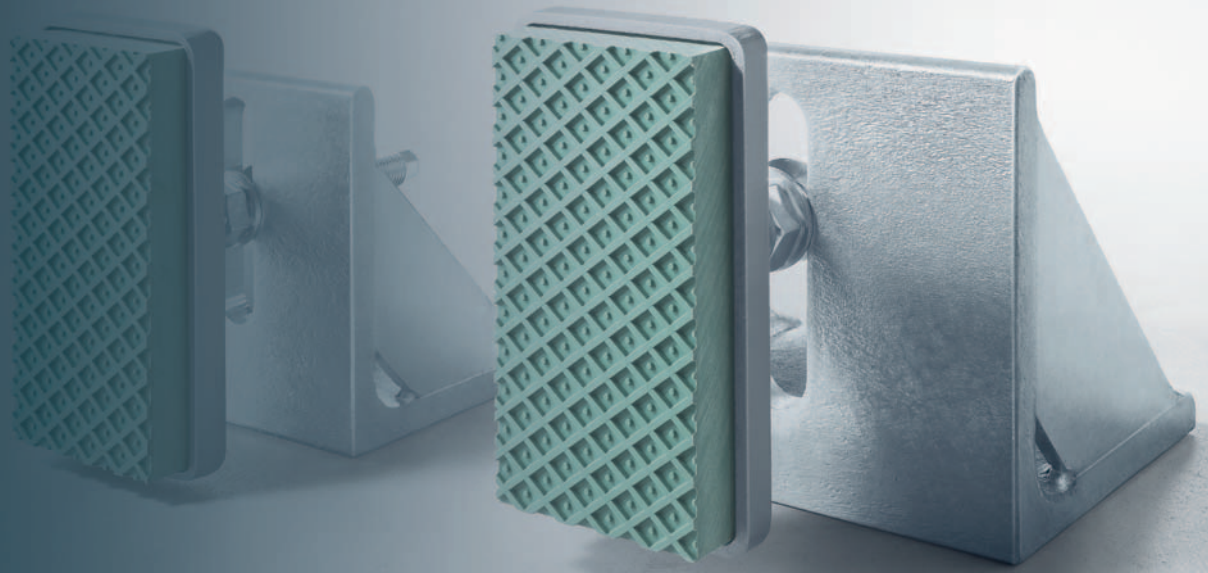

SIZE 1

Type	Item no.	max. load N/Stk.	a mm	b mm	c mm	d mm	e mm	f mm	g mm	i mm
Size 1	20-0066	16.500	140	125	75-95	45-115	50	25	35	18

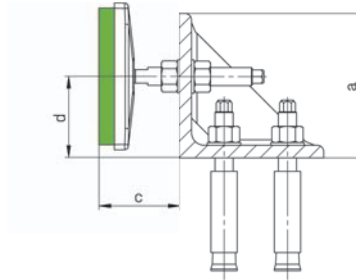
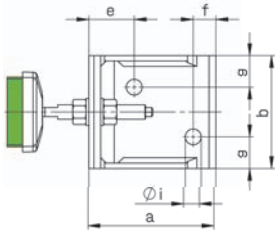

SIZE 2

Type	Item no.	max. load N/Stk.	a mm	b mm	c mm	d mm	e mm	f mm	g mm	i mm
Size 2	20-0067	16.500	160	180	75-95	46-130	50	40	35	22

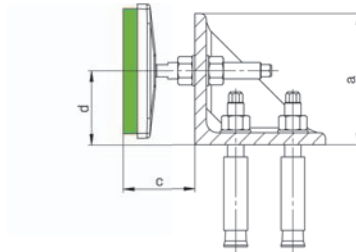
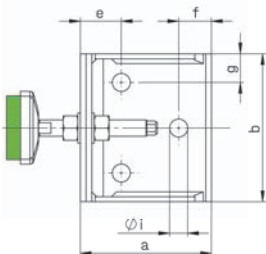

AIR SPRINGS

(RUBBER/MEMBRANE AIR SPRINGS)

HIGHLY EFFECTIVE INSULATION OF VIBRATIONS AND STRUCTURE-BORNE NOISE FOR A WIDE VARIETY OF MACHINE MODELS, OPTICAL AND ELECTRONIC DEVICES, LASER SYSTEMS AS WELL AS VEHICLE, ENGINE AND TRANSMISSION TEST BENCHES.



All information about our rubber springs is also available on our website.

The use of Bilz air spring insulators with active level control constantly maintains the correct level of machines or foundations. The level control and adjustment is entirely automatic.

The pressure in the air springs is appropriately adjusted by pressurising or venting in response to load changes. This keeps the insulating effect constant in all events.

Unlike steel springs air springs do not transmit structure-borne sound.

RUBBER AIR SPRING INSULATORS

for highly effective shock and vibration insulation

- FAEBI[®] rubber air springs are used for the highly effective insulation of machines, apparatus and aggregates from shocks, vibrations and structure-borne noise.
- The element comprises of a bellshaped rubber form made from high-grade elastomer.
- The constructive design enables highly effective vibration insulation without the disadvantage of high horizontal deflection.
- Overloading of the element due to a sudden pressure drop is virtually impossible.
- On request, the system is also available with mechanical or electronic level control (see under "Accessories", page 46).
- The base pad is equipped with an anti-slip pad to eliminate the need for floor anchoring.
- The FAEBI[®] rubber air spring is also available in a stainless steel version for use in outdoor areas (e.g. air-conditioning technology).



APPLICATIONS FOR RUBBER SPRINGS

Perfectly suited for source insulation of fast running presses, forging hammers and other machines and aggregates with highly dynamic disturbance forces. Passive insulation of measuring and test equipment as well as highly accurate machine tools.

SHOCK AND VIBRATION INSULATION WITH RUBBER AIR SPRINGS

The natural frequency of the rubber air spring in the vertical direction is between 3 and 14 Hz depending on the static load. The maximum spring deflection in response to a pulse load is up to 15mm depending on the model and size of the air spring.

AIR PRESSURE CONTROL

FAEBI® elements can be equipped with an air pressure control on request. The air pressure monitor will indicate if the air pressure falls below the required set point.

BILZ LEVEL CONTROL SYSTEMS

The level control is a significant component to ensure the optimal function of an air spring system. The level control can correct load changes that cause undesired deflection of the air elements or inclination of the machine in a machine or system equipped with air springs.

NOTES

Selection and notes on the FAEBI® variants

Please select a suitable rubber air spring so that the maximum load (sum of static and dynamic load) is not exceeded. In applications with high dynamics, harder FAEBI® variants reduce the deflection of the insulators, but the achievable insulating effect is better with softer insulators.

Please get in touch, we would be happy to assist you in selecting the most suitable elements.

- If the bottom edge of the machine does not completely cover the diameter ($\varnothing D$ - see p. 40) of the rubber air spring, we recommend the use of our special cover (see "Accessories" section on page 45-47).
- The elements are attached to the holes provided on the machine using the bolts supplied. Anchoring to the floor is usually not necessary.
- Please bolt in by hand only, do not use a wrench! Please also fasten the corresponding nut with low torque only.
- The machine is placed on the deflated element, which is then inflated in stages using the standard valve until dimension H (= working height) is reached. The maximum specified air pressure must also not be exceeded!
- Ventilation and venting may only take place under load (please observe max. permissible pressure)!
- Up to +/-5mm are available for levelling.

SERIES FAEBI®

FAEBI® rubber air spring insulator

FAEBI®

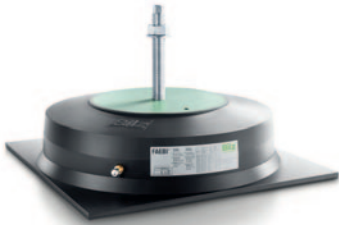

FAEBI® WITH LEVEL CONTROL



The FAEBI® element is available in many different sizes and versions to suit your application.

Advantages over steel springs

Compared to steel springs, the use of air springs offers numerous advantages in vibration insulation:

- Flexible design of the insulation system: If the static or dynamic load changes, the deflection can be adjusted accordingly by adjusting the air pressure. This can be done either manually or automatically (e.g. by Bilz level control).
- Integrated damping, therefore separate insulation is not necessary.
- No transmission of structure-borne noise.
- Permissible temperature range: -20 °C to +60 °C.

NATURAL FREQUENCIES FAEBI® 50 TO 580

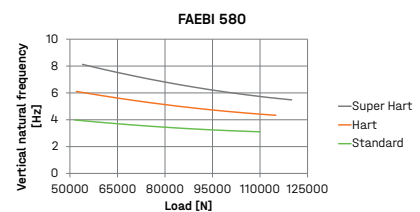
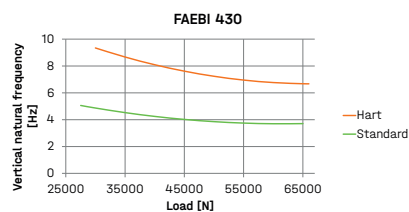
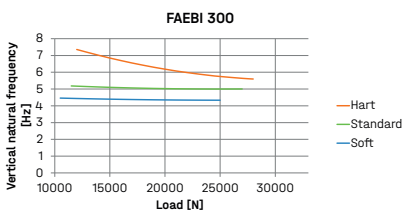
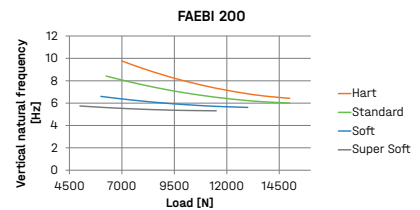
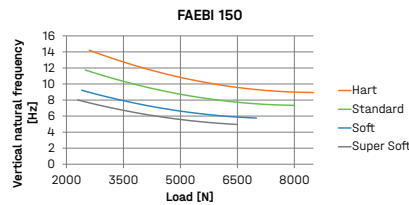
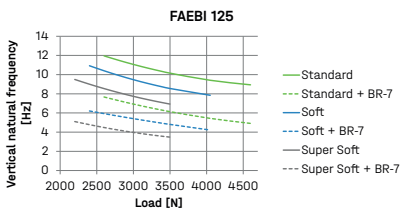
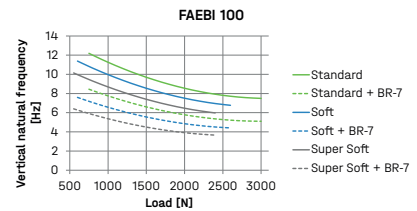
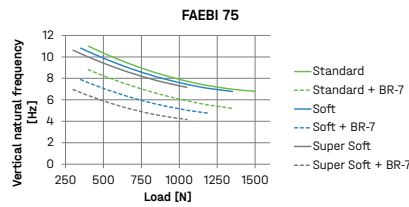
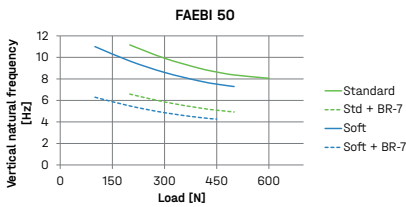

SERIES FAEBI® IN STAINLESS STEEL

FAEBI® rubber air spring insulator in stainless steel

FAEBI® IN STAINLESS STEEL



FAEBI® elements in the VA version were specifically developed for outside applications. Effortless vibration insulation of systems in the open air such as air conditioning units, compressors, heat exchangers, cold water chillers.

Advantages over steel springs

Compared to steel springs, the use of air springs offers numerous advantages in vibration insulation:

- Flexible design of the insulation system: If the static or dynamic load changes, the deflection can be adjusted accordingly by adjusting the air pressure. This can be done either manually or automatically (e.g. by Bilz level control).
- Can be used in outdoor areas in combination with a stainless steel protective hood.
- Integrated damping, therefore separate insulation is not necessary.
- No transmission of structure-borne noise.
- Permissible temperature range: -20 °C to +60 °C.

NATURAL FREQUENCIES FAEBI® 50 TO 300 IN STAINLESS STEEL

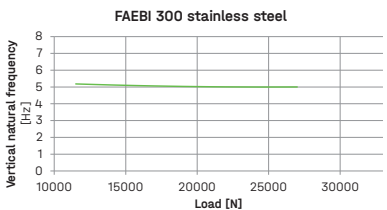
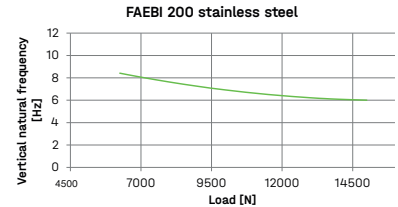
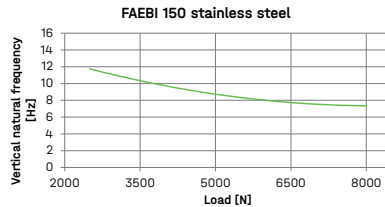
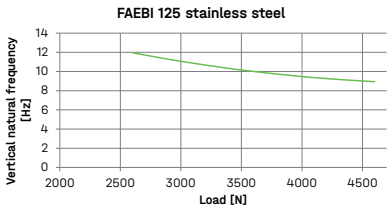
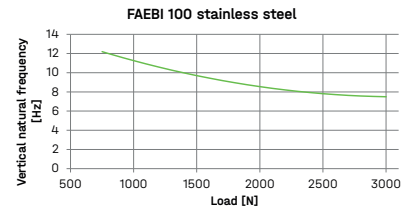
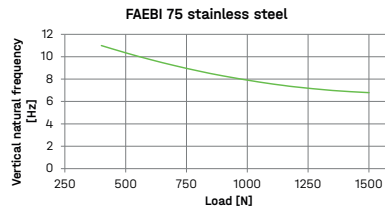
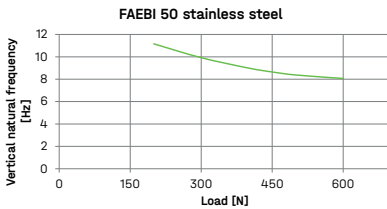

VARIANTS AND ARTICLE NUMBERS OF THE FAEBI® AND FAEBI® STAINLESS STEEL SERIES

Type	Variant	Item no. FAEBI®	Item no. FAEBI® in Stainless steel	load N/pc.	max. pressure bar	A mm	Ø D mm	H approx. mm = working height	H (deflated) mm	Ø d mm	h mm	G mm
FAEBI® 50	Standard	40-0071	40-0075	200-600	3	110	85	60	61	35	5	M10
	Standard + BR7-1	40-0134		200-500	2,5	110	85	62	68	35	5	M10
	Soft	40-0072		100-500	2,5	110	85	60	61	35	5	M10
	Soft + BR7-1	40-0135		100-450	2,3	110	85	62	68	35	5	M10
FAEBI® 75	Standard	40-0082	40-0086	400-1.500	3	115	100	63	67	43	5	M12
	Standard + BR7-1	40-0136		400-1.350	2,7	115	100	65	74	43	5	M12
	Soft	40-0084		350-1.300	2,6	115	100	63	67	43	5	M12
	Soft + BR7-1	40-0137		350-1.200	2,4	115	100	65	74	43	5	M12
	Super Soft	40-0083		300-1.050	2,1	115	100	63	67	43	5	M12
FAEBI® 100	Super Soft + BR7-1	40-0138		300-1.050	2,1	115	100	65	74	43	5	M12
	Standard	40-0024	40-0030	750-3.000	5	135	120	62	65	60	5	M12
	Standard + BR7-1	40-0139		750-3.000	5	135	120	64	72	60	5	M12
	Soft	40-0026		600-2.600	4,4	135	120	62	65	60	5	M12
	Soft + BR7-1	40-0140		600-2.600	4,4	135	120	64	72	60	5	M12
FAEBI® 125	Super Soft	40-0025		550-2.400	4	135	120	62	65	60	5	M12
	Super Soft + BR7-1	40-0141		550-2.400	4	135	120	64	72	60	5	M12
	Standard	40-0033	40-0036	2.600-4.600	5,5	165	140	93	98	66	5	M16
	Standard + BR7-1	40-0142		2.600-4.600	5,5	165	140	95	105	66	5	M16
	Soft	40-0035		2.400-4.050	4,9	165	140	93	98	66	5	M16
FAEBI® 150	Soft + BR7-1	40-0143		2.400-4.050	4,9	165	140	95	105	66	5	M16
	Super Soft	40-0034		2.200-3.500	4,2	165	140	93	98	66	5	M16
	Super Soft + BR7-1	40-0144		2.200-3.500	4,2	165	140	95	105	66	5	M16
	Hard	40-0043		2.600-8.500	6,4	200	170	91	96	80	8	M16
FAEBI® 200	Standard	40-0037	40-0042	2.500-8.000	6	200	170	91	96	80	8	M16
	Soft	40-0040		2.400-7.000	5,3	200	170	91	96	80	8	M16
	Super Soft	40-0038		2.300-6.500	4,9	200	170	91	96	80	8	M16
FAEBI® 300	Hard	40-0051		7.000-15.000	6	260	236	91	95	130	8	M16
	Standard	40-0046	40-0050	6.250-15.000	6	260	236	91	95	130	8	M16
	Soft	40-0048		6.000-13.000	5,2	260	236	91	95	130	8	M16
	Super Soft	40-0047		5.500-11.500	4,6	260	236	91	95	130	8	M16
FAEBI® 430	Hard	40-0058		12.000-28.000	6,5	370	340	89	93	200	8	M20
	Standard	40-0055	40-0057	11.500-27.000	6	370	340	89	93	200	8	M20
	Soft	40-0056		10.500-25.000	5,6	370	340	89	93	200	8	M20
FAEBI® 580	Hard	40-0065		30.000-66.000	6,1	500	480	89	94	315	12	M20
	Standard	40-0064		27.500-65.000	6	500	480	89	94	315	12	M20
FAEBI® 580	Super Hard	40-0079		54.000-120.000	6,6	680	650	89	91	380	14	M24
	Hard	40-0078		52.000-115.000	6,3	680	650	89	91	380	14	M24
	Standard	40-0076		51.500-110.000	6	680	650	89	91	380	14	M24

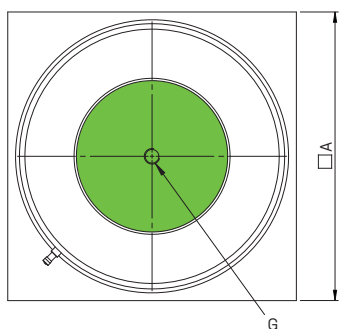

SETTING CURVE FAEBI®

without adjustable damping (single chamber system)

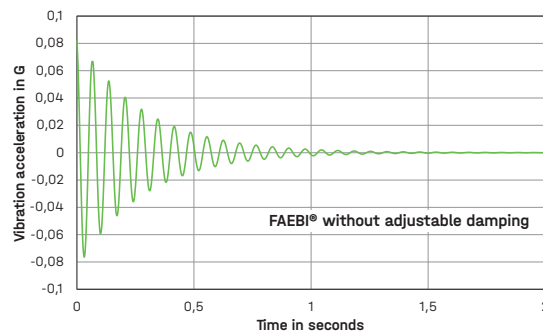

SERIES FAEBI®-HD

with adjustable damping

FAEBI®-HD WITH ADJUSTABLE DAMPING



Extra high air cushioning due to two-chamber system.

For reducing the amplitudes of movement in highly dynamic systems, also in the resonance range, thus reducing machine wear and improving production quality.

Description

- Wear-resistant, low-maintenance air damping, easy to adjust from the outside using the throttle valve.
- Rapid machine movement reduction due to increased energy absorption.
- Deflection characteristics can be adapted by adjusting the air pressure.
- No transmission of structure-borne noise.
- Permissible temperature range: -20 °C to +60 °C.

NATURAL FREQUENCIES FAEBI® 200-HD TO 580-HD

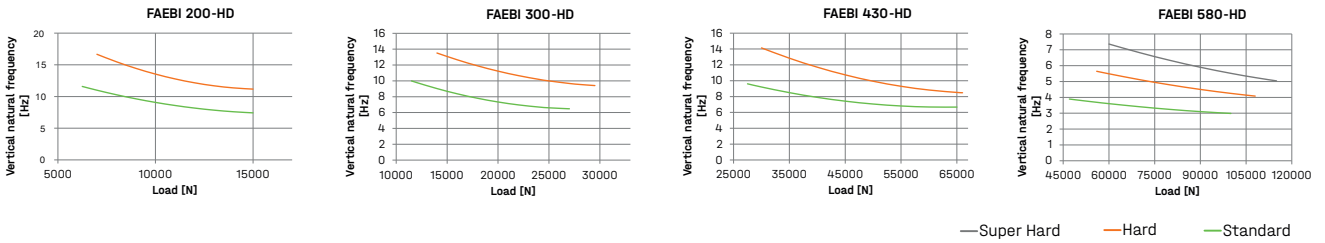

VARIANTS AND ARTICLE NUMBERS OF THE FAEBI®-HD SERIES

Type	Variant	Item no.	load N/pc.	max. pressure bar	A mm	Ø D mm	H approx. mm = working height	H (deflated) mm	Ø d mm	h mm	G mm
FAEBI® 200-HD	Hard	40-0054	7.000 -15.000	6	260	236	89	90	130	8	M16
	Standard	40-0053	6.250 -15.000	6	260	236	89	90	130	8	M16
FAEBI® 300-HD	Hard	40-0063	14.000 - 29.500	6,5	370	340	89	94	200	8	M20
	Standard	40-0061	11.500 - 27.000	6	370	340	89	93	200	8	M20
FAEBI® 430-HD	Hard	40-0070	30.000 - 66.000	6,1	500	480	91	97	315	12	M20
	Standard	40-0067	27.500 - 65.000	6	500	480	91	96	315	12	M20
FAEBI® 580-HD	Super Hard	40-0081	60.000 - 115.000	6,9	680	650	126	135	380	14	M24
	Hard	40-0145	56.000 - 108.000	6,5	680	650	126	133	380	14	M24
	Standard	40-0080	47.000 - 100.000	6	680	650	126	130	380	14	M24

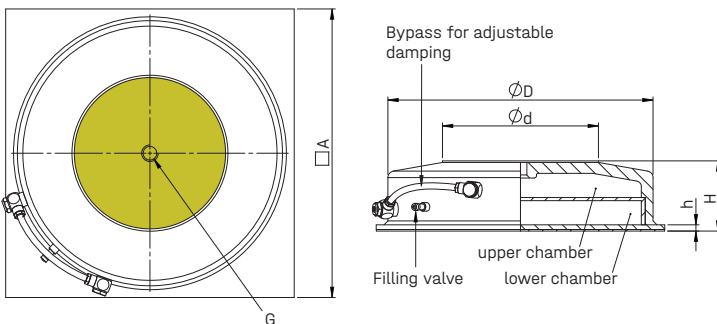

SETTING CURVE FAEBI®-HD

with adjustable damping (two-chamber system)

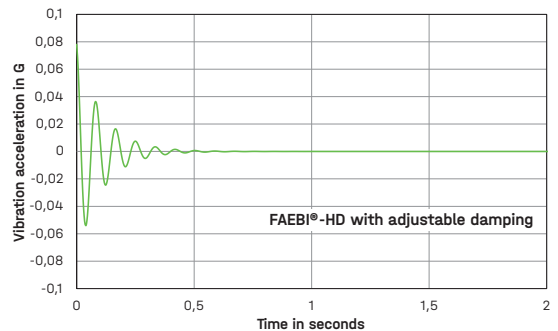

MEMBRANE AIR SPRINGS

for effective vibration damping and insulation

- With our BiAir® air spring insulator, the air volume is enclosed by a thin-walled, flexible and pressure-resistant rolling membrane.
- The piston sits on the membrane and is pressed into place by the air volume.
- This constructional design enables highly effective vibration insulation.

APPLICATIONS FOR MEMBRANE AIR SPRINGS

For highly effective receiver insulation of measuring and testing machines, inspection and production machines in the semiconductor industry, optical and electronic devices, laser systems, precision machining machines, as well as vehicle, engine and gearbox test tables etc.

HOW THE MEMBRANE AIR SPRINGS WORK

In order to simultaneously achieve the highest degree of damping possible, the air space is divided into two chambers (load/damping volume) connected by a bypass. An adjustable throttle valve is used from the outside to set the flow cross-section in the connecting line of the bypass to the desired damping. A degree of damping of up to 15% is possible.

GENERAL INFORMATION ON THE SELECTION AND APPLICATION OF OUR BIAIR® MEMBRANE AIR SPRINGS

- The maximum permissible movement amplitude in the horizontal plane is between approximately 1 to 2mm depending on the size of the air spring.
- In addition to the standard solutions listed here we also offer numerous air springs with a larger stroke and lower natural frequency.
- Please select the load at an air pressure of 4 bar when selecting the air spring size.
- The powder coated air springs are also available in other RAL colours on request.
- Permissible temperature range: -20 °C to +80 °C.
- Damage to the rolling membrane due to overpressure is virtually impossible through the use of additional safety valves or a mechanical piston stroke limit.

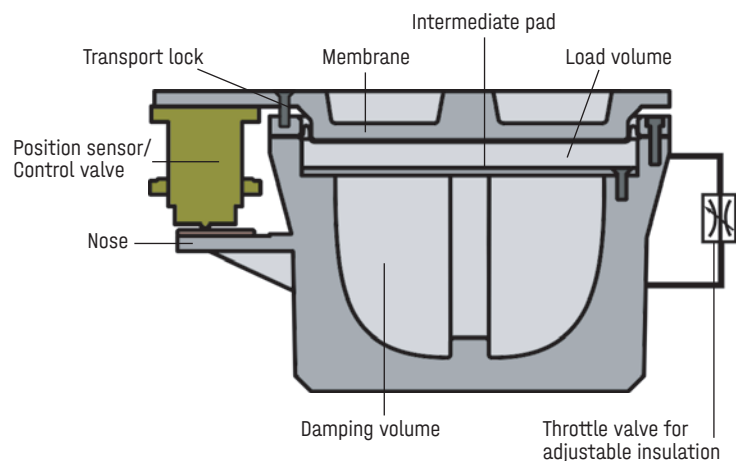

SERIES BIAIR®-ED-AL IN ANODISED ALUMINIUM



Low-frequency (**vertical from 2.5 Hz**) membrane air spring with precisely adjustable damping for effective vibration isolation.

Made from anodised aluminium to meet high demands on material properties.

Variants with lug for mounting valves (MPN) or displacement sensors are available with hose connections on the left (NL) or right (NR) on request.

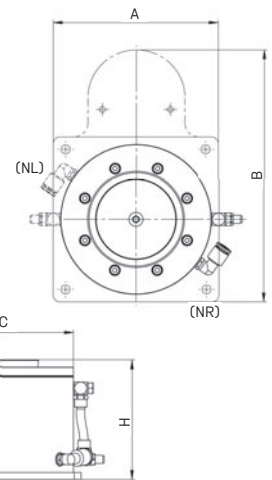

VARIANT SELECTION AND ITEM NUMBERS BIAIR®-ED-AL

Type	Item no. without nose	Item no. NR	Art.-Nr NL	Natural frequency vertical/horizontal HZ	A mm	B mm	Ø C mm	Working height H mm	+/- Travel mm	max. load N / 4 bar*	max. load N / 6 bar*
0,125	50-0002	-	-	3,0/3,5	75	-	74	77	+/- 2,0	390	580
0,15	50-0005	-	-	3,0/3,5	75	-	74	77	+/- 2,0	670	1.000
0,25	50-0129	50-0135	50-0136	3,0/3,5	120	182	110	87	+/- 2,5	1.130	1.700
0,5	50-0130	50-0137	50-0138	2,5/2,8	130	198	129	100	+/- 2,5	2.670	4.000
1	50-0131	50-0139	50-0140	2,5/2,8	200	275	200	100	+/- 2,5	6.330	9.500
1,5	50-0146	50-0147	50-0147	2,5/2,8	230	305	230	100	+/- 3,5	10.170	15.260
2	50-0133	50-0141	50-0141	2,5/2,8	260	350	260	100	+/- 2,5	14.200	21.300
2,5	50-0134	50-0142	50-0142	2,5/2,8	300	390	300	100	+/- 3,0	19.670	29.500

* max. load N at an air pressure of 4 bar or 6 bar

- max. working height 100mm
- Load-independent natural frequency
- Wear-resistant, low-maintenance air damping, easy to adjust from the outside
- No transmission of structure-borne noise

SERIES BIAIR®-ED MADE FROM CAST ALUMINIUM



Low-frequency (**vertical 2.5 Hz**) membrane air spring with precisely adjustable damping for effective vibration isolation.

Made from cast aluminium, universally applicable.

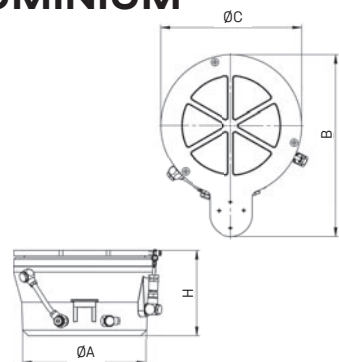

VARIANT SELECTION AND ITEM NUMBERS BIAIR®-ED

Type	Item no.	Natural frequency vertical/horizontal HZ	A mm	B mm	Ø C mm	Working height H mm	+/- Travel mm	max. load N / 4 bar*	max. load N / 6 bar*
0,5	50-0012	2,5/2,8	120	216	129	157	+/- 2,5	2.670	4.000
1	50-0026	2,5/2,8	172	288	200	157	+/- 2,5	6.330	9.500
1,5	50-0191	2,5/2,8	212	305	230	157	+/- 3,5	10.170	15.260
2	50-0188	2,5/2,8	226	335	260	157	+/- 2,5	14.200	21.300
2,5	50-0036	2,5/2,8	271	378	300	157	+/- 3,0	19.670	29.500
3	50-0055	2,5/2,8	348	467	382	157	+/- 2,5	34.130	51.200
4	50-0064	2,5/2,8	490	605	530	157	+/- 2,75	65.730	98.600
5**	50-0072	2,5/2,8	747	875	798	157	+/- 3,5	155.730	233.600

* max. load N at an air pressure of 4 bar or 6 bar

**unlacquered

- max. working height 157mm
- Load-independent natural frequency
- Wear-resistant, low-maintenance air damping, easy to adjust from the outside.
- No transmission of structure-borne noise.
- Powder coated in RAL similar to 7037, dusty grey.

SERIES BIAIR[®]-ED-HE MADE FROM CAST ALUMINIUM



Very low-frequency (**vertical 1.7 Hz**) membrane air spring with precisely adjustable damping for effective vibration isolation.
Made from cast aluminium, universally applicable.

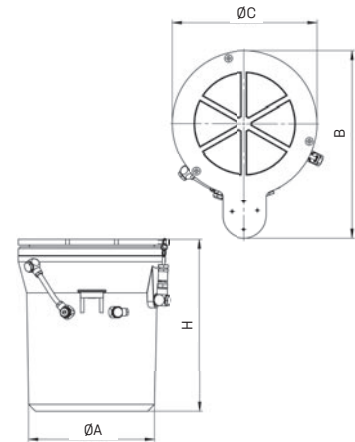

VARIANT SELECTION AND ITEM NUMBERS BIAIR[®]-ED-HE

Typ	Item no.	Natural frequency vertical/horizontal Hz	A mm	B mm	Ø C mm	Working height H mm	+/- Travel mm	max. load	max. load
								N / 4 bar*	N / 6 bar*
0,5**	50-0145	1,7/2,8	129	216	129	307	+/- 2,5	2.670	4.000
1	50-0027	1,7/2,8	172	288	200	307	+/- 2,5	6.330	9.500
1,5	50-0021	1,7/2,8	212	305	230	307	+/- 3,5	10.170	15.260
2	50-0046	1,7/2,8	226	335	260	307	+/- 2,5	14.200	21.300
2,5	50-0037	1,7/2,8	271	378	300	307	+/- 3,0	19.670	29.500
3	50-0056	1,7/2,8	348	467	382	307	+/- 2,5	34.130	51.200
4	50-0065	1,7/2,8	490	605	530	307	+/- 2,75	65.730	98.600

* max. load N at an air pressure of 4 bar or 6 bar
** unlacquered, made of aluminium

- max. working height 307mm
- Load-independent natural frequency
- Wear-resistant, low-maintenance air damping, easy to adjust from the outside
- No transmission of structure-borne noise
- Powder coated in RAL similar to 7037, dusty grey

SERIES BIAIR[®]-ED-HE-MAX MADE FROM CAST ALUMINIUM



Very low-frequency (**vertical 1.2 Hz**) membrane air spring with precisely adjustable damping for effective vibration isolation.
Made from cast aluminium, universally applicable.

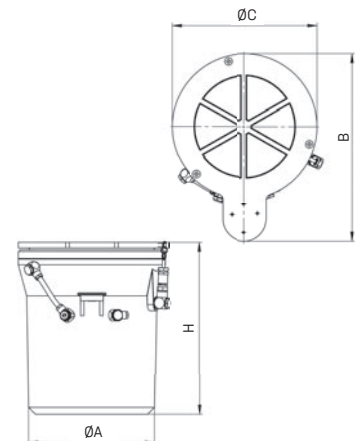

VARIANT SELECTION AND ITEM NUMBERS BIAIR[®]-ED-HE-MAX

Type	Item no.	Natural frequency vertical/horizontal Hz	Ø A mm	B mm	Ø C mm	Working height H mm	+/- Travel mm	max. load	max. load
								N / 4 bar*	N / 6 bar*
1	50-0372	1,2/2,8	172	288	200	509	+/- 2,5	6.330	9.500
1,5	50-0373	1,2/2,8	212	305	230	509	+/- 3,5	10.170	15.260
2	50-0374	1,2/2,8	226	335	260	509	+/- 2,5	14.200	21.300
2,5	50-0375	1,2/2,8	271	378	300	509	+/- 3,0	19.670	29.500
3	50-0376	1,2/2,8	348	467	382	509	+/- 2,5	34.130	51.200
4	50-0335	1,2/2,8	490	605	530	509	+/- 2,75	65.730	98.600
5	50-0073**	1,2/2,8	728	960	880	509	+/- 3,5	155.730	233.600

* max. load N at an air pressure of 4 bar or 6 bar
** unlacquered

- max. working height 509 mm
- Load-independent natural frequency
- Wear-resistant, low-maintenance air damping, easy to adjust from the outside
- No transmission of structure-borne noise
- Powder coated in RAL similar to 7037, dusty grey

ACCESSORIES

Our accessories complete the performance requirements of our air springs and consequently support an ideal vibration isolation.

FIXING BOLTS



The FAEBI® rubber air springs are attached to the existing holes in the machine using the bolts provided (incl. one nut and one washer each). Anchoring to the floor is usually not necessary. A large range of different bolts are available for each variant. We are always happy to offer our advice.

ITEM NUMBERS

FAEBI®	Item no.	Thread	Material	Length mm
FAEBI® 50	19-0311	M10	Galvanised steel	100
FAEBI® 75/100	19-0322	M12	Galvanised steel	100
FAEBI® 125/150/200	19-0324	M16	Galvanised steel	125
FAEBI® 300/430	19-0327	M20	Galvanised steel	150
FAEBI® 580	19-0329	M24	Galvanised steel	150

FAEBI® Edelstahl VA	Item no.	Thread	Material	Length mm
FAEBI® 50 VA	18-0005	M10	Stainless steel	100
FAEBI® 75/100 VA	18-0016	M12	Stainless steel	100
FAEBI® 125/150/200 VA	18-0066	M16	Stainless steel	125
FAEBI® 300/430 VA	18-0044	M20	Stainless steel	150
FAEBI® 580 VA	18-0052	M24	Stainless steel	150

FAEBI®-HD	Item no.	Thread	Material	Length mm
FAEBI® 200-HD	19-0324	M16	Galvanised steel	125
FAEBI® 300-HD/430-HD	19-0327	M20	Galvanised steel	150
FAEBI® 580-HD	19-0329	M24	Galvanised steel	150

PRESSURE CONTROL



Suitable for all rubber air springs.

Applications with a constant centre of gravity during the production/testing process (no moving machine components, workpieces, etc., steady masses).

Difficult to access systems, where the manual checking of air pressure in the air springs is impeded.

Item numbers:

3 Pressure regulator incl. pneumatic connection and hose set:
Item no. 40-0179

4 Pressure regulator incl. pneumatic connection and hose set:
Item no. 40-0180

The Bilz pressure control is the ideal addition to applications that do not need automatic level control.

Instead of filling the air springs manually, they are connected to a constant compressed air supply. The working height of the individual insulators can each be individually set with one pressure regulator.

Advantages of FAEBI® pressure control

- Simple and precise setting of the required pressure for each air spring or control group.
- Low maintenance.
- Manometer for continuous pressure indication.
- Upstream particle filter and water separator.
- Can be configured for any number of air springs or control groups.

HAND PUMP



Suitable for all rubber air springs.

Item no. 40-0128

Hand pump for manual air filling.

ACCESSORIES

COMPRESSED AIR GUN



Suitable for all rubber air springs.
Item no. 40-0089

Compressed air gun with pressure gauge for air filling via existing compressed air supply.

MECHANICAL-PNEUMATIC LEVEL CONTROL SYSTEMS



MPN-LCV for FAEBI® and FAEBI®-HD Rubber air spring insulators:
Item no. 61-0103
 Standard version of the LCV with stainless steel washer

MPN-LCV

The mechanical-pneumatic level control MPN-LCV with our robust LCV proportional valves is a simple but effective solution to prevent tilting as a result of load changes. The target level is adjusted by turning the knurled adjustment ring and is maintained with an accuracy of $\pm 1/10\text{mm}$.

MPN-LCV for BiAir® membrane air springs: **Item no. 61-0012**
 Standard version LCV with stainless steel washer

MPN-LCV-short-Pad-A for BiAir® membrane air springs:
Item no. 61-0054
 Shortened version of the LCV with plunger insulation pad.

MECHANICAL-PNEUMATIC LEVEL CONTROL SYSTEMS



MPN-PVM for BiAir® membrane air springs: **Item no. 61-0010**
 Standard version PVM with hard metal washers

MPN-PVM

The mechanical-pneumatic level control MPN-PVM with our robust PVM proportional valves is a simple but effective solution to prevent tilting as a result of load changes. The target level is adjusted and maintained by turning the knurled adjustment ring.

MPN-PVM-short-Pad-A for BiAir® membrane air springs:
Item no. 61-0058
 Shortened version of the PVM with plunger insulation pad

High-precision proportional valve.
 The reset accuracy is $\pm 1/100\text{mm}$.

ELECTRONIC-PNEUMATIC LEVEL CONTROL SYSTEMS



Suitable for all membrane air springs.

ELECTRONIC-PNEUMATIC POSITION CONTROL EPPC™

EPPC™ real-time level control for efficient vibration insulation of vibration sensitive, highly dynamic machines and strict requirements on positional accuracy and setting time.

Further details regarding the BiAir® membrane air springs with electronic-pneumatic level control can be found in the chapter EPPC™ on pages 52-53.

PROTECTIVE COVER

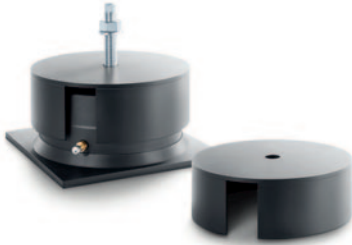

Material:
Steel sheet (primed black)
For Faebi® and Faebi®-HD



Material:
Stainless steel
For FAEBI® In stainless steel

If the surface of the FAEBI® elements is not completely covered by the bottom edge of the machine or the installation surface, an appropriate cover is required to ensure sufficient load distribution across the air spring. A hood will also provide protection from external damage.

For outdoor use, the hood is additionally equipped with a protective sleeve that protects against UV radiation and splash water.

ITEM NUMBERS - COVER FOR FAEBI® AND FAEBI®-HD

Type	Item no.	A mm	D mm	s mm	h mm	d mm
AH-FAEBI® 50 / 75	40-0013	13	115	5	40	2
AH-FAEBI® 100	40-0001	14	140	5	45	2
AH-FAEBI® 125	40-0003	18	160	5	60	2
AH-FAEBI® 150	40-0006	18	190	5	60	2
AH-FAEBI® 200	40-0007	18	255	5	60	3
AH-FAEBI® 300	40-0009	22	360	5	60	3
AH-FAEBI® 430	40-0012	22	500	10	60	4
AH-FAEBI® 580	40-0014	27	680	10	60	4

ITEM NUMBERS - COVER FOR FAEBI® IN STAINLESS STEEL

Type	Item no.	Application	A mm	D mm	s mm	h mm	d mm
AH-Stainless steel FAEBI® 50 / 75	40-0163	Indoor	13	115	5	40	2
AH-Stainless steel FAEBI® 100	40-0002	Indoor	14	140	5	45	2
AH-Stainless steel FAEBI® 125	40-0004	Indoor	18	160	5	60	2
AH-Stainless steel FAEBI® 150	40-0005	Indoor	18	190	5	60	2
AH-Stainless steel FAEBI® 200	40-0008	Indoor	18	255	5	60	3
AH-Stainless steel FAEBI® 300	40-0010	Indoor	22	360	5	60	3

with protective sleeve

AH-Stainless steel FAEBI® 50 / 75	77-0016	Outdoor	13	115	5	40	2
AH-Stainless steel FAEBI® 100	77-0017	Outdoor	14	140	5	45	2
AH-Stainless steel FAEBI® 125	77-0018	Outdoor	18	160	5	60	2
AH-Stainless steel FAEBI® 150	77-0019	Outdoor	18	190	5	60	2
AH-Stainless steel FAEBI® 200	77-0020	Outdoor	18	255	5	60	3
AH-Stainless steel FAEBI® 300	77-0021	Outdoor	22	360	5	60	3

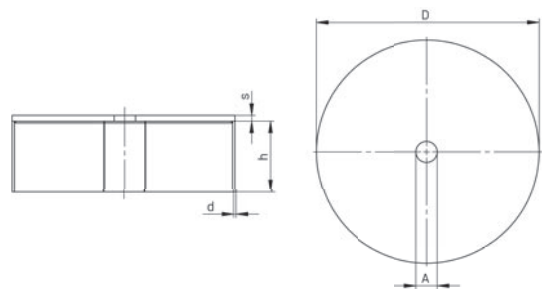

MECHANICAL LEVEL CONTROL SYSTEMS

EFFICIENT LEVEL CONTROL SYSTEMS FOR AIR SPRING INSULATORS COMBINED WITH THE HIGHEST LEVELLING CONSTANCY.



All information on our mechanical level control systems can also be found on our website.

Mechanical-pneumatic level control systems from Bilz are an essential component for the optimum functioning of a vibration insulation system using the FAEBI® and FAEBI®-HD rubber air springs or BiAir® membrane air springs.

They prevent impermissible deflection of the insulators or inclination of the machine caused by load changes on a machine or an air spring-mounted machine or system.

NOTES

- Supplied as a complete set which includes the 3 control valves and all necessary hose lines and connectors for 4 air springs. All components are also available individually as spare parts.
- On the LCV variant the air flow can be reduced using the throttle valve should the control system tend to overshoot. The PVM variant can also be fitted with a throttle valve as an option.
- In addition to the standard solutions listed here we also hold special versions with regard to material, flow, accuracy and restoring force.



Level control system (PVM version)



Level control system (Variante PVM)



Level control system
(PVM version with ducted exhaust air)



FUNCTION OF THE VALVES

The level is continuously sensed by means of a plunger. The position of the plunger is directly applied to the slide valve. The air spring supplied with compressed air via the valve is pressurised or vented according to the position of the valve slide. The target level is adjusted by turning the knurled adjustment ring. The height and level of the machine is adjusted using three valves.

FUNCTION OF THE MECHANICAL-PNEUMATIC LEVEL CONTROL SYSTEMS

The valves are used to adjust and automatically regulate the air pressure inside the insulators according to the respective load by means of rapid ventilation and venting. This enables the highest degree of stability and effective insulation even with changes in the centre of gravity.

DESIGN

A level control system consists of at least three mechanical-pneumatic valves and three air springs (Fig. 1). If more insulators are required due to reasons of design or load, the system must still be operated in three controlled groups (Fig. 2), as otherwise it is statically overdetermined. This is achieved by using multiple insulators in parallel as a group (Fig. 2). Optionally, an additionally available maintenance unit for compressed air preparation can be connected upstream of the control valves.

Fig. 1

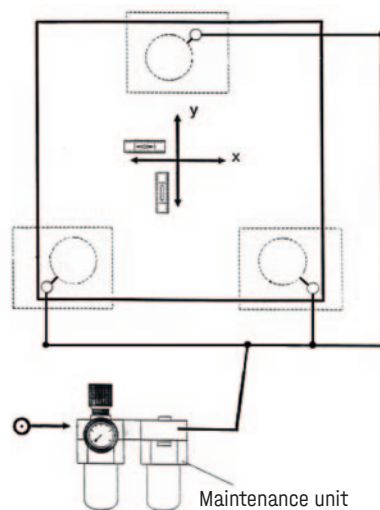
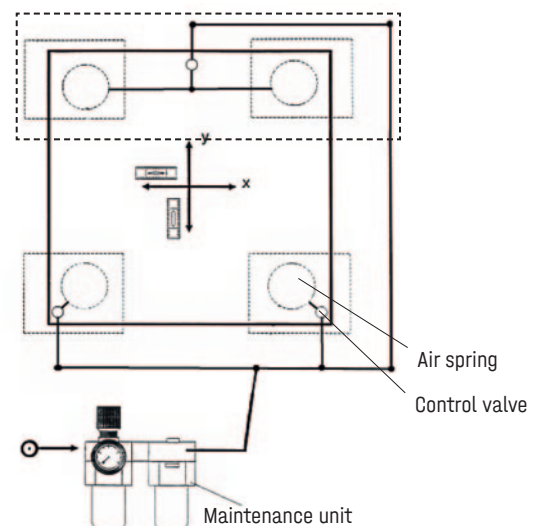

Fig. 2



MECHANICAL-PNEUMATIC LEVEL CONTROL SYSTEMS (MPN)

Proportional valves to prevent tilting as a result of load changes. The level is continuously sensed by means of a plunger. The position of the plunger is directly applied to the valve and the air spring is pressurised or vented respectively. The target level is adjusted by turning the knurled adjustment ring and is maintained with an accuracy of $\pm 1/10\text{mm}$ (MPN-LCV), or $\pm 1/100\text{mm}$ (MPN-PVM). Three control valves are used, which can be connected to an additionally available maintenance unit for compressed air preparation. This limits the system pressure to max. 6 bar, removes any condensate and cleans the compressed air of solid particles (rust and dust).

MPN-LCV



Standard solutions

MPN-LCV for FAEBI® and FAEBI®-HD rubber air springs:

Item no. 61-0103

Standard version of the LCV with stainless steel washer.

MPN-LCV for BiAir® membrane air springs:

Item no. 61-0012

Standard version of the LCV with stainless steel washer.

MPN-LCV-short-Pad-A for BiAir® membrane air springs:

Item no. 61-0054

Shortened version of the LCV with plunger insulation pad.

- Extremely robust galvanised proportional valve
- The reset accuracy is $\pm 1/10\text{mm}$
- The air flow can be reduced using the throttle valve should the control system tend to overshoot.
- Compressed air quality must be in accordance with ISO 8573-1:2010 in order to operate the air elements: Air class 3.4.3
- Supplied as a complete set which includes the 3 control valves and all necessary hose lines and connectors for 4 air springs.
- All components are also available individually as spare parts.
- In addition to the standard solutions listed here we also hold special versions with regard to material, flow, accuracy and restoring force.

MPN-PVM



MPN-PVM for BiAir® membrane air springs:

Item no. 61-0010

Standard version of the PVM with hard metal washer.

MPN-PVM-short-Pad-A for BiAir® membrane air springs:

Item no. 61-0058

Shortened version of the PVM with plunger insulation pad.

- High-precision proportional valve
- The reset accuracy is $\pm 1/100\text{mm}$
- Compressed air quality must be in accordance with ISO 8573-1:2010 in order to operate the air elements: Air class 2.4.2, below 15 °C: Air class 2.3.2
- Supplied as a complete set which includes the 3 control valves and all necessary hose lines and connectors for 4 air springs. All components are also available individually as spare parts.
- Available as an option: Throttle valve for reducing the air volume flow should the control system tend to overshoot.
- In addition to the standard solutions listed here we also hold special versions with regard to material, flow, accuracy and restoring force.

ACCESSORIES

Our accessories complement the requirements of our mechanical-pneumatic level control systems.

MAINTENANCE UNITS



Version with filter (up to 5 µm) for MPN-LCV.

WFD-M:
Item no. 61-0140



Version with additional fine filter (up to 1 µm) for MPN-PVM.

WFD-M-PVM:
Item no. 61-0048



Version with additional ultrafine filter (up to 0.01 µm) for polluted, oily air.

WFD-M-PVM oil filter:
Item no. 61-0049

ANTI-TRAPPING PROTECTION



Anti-trapping protection incl. compatible hard metal disc, per valve:

Item no. 50-0276

BELLOWS



For LCV valve:
Item no. 66-0001

For PVM valve:
Item no. 78-0038

WITH PRESSURE REGULATOR AND FILTER

The air maintenance units are used to set the optimum system pressure and prepare the compressed air for the air spring system. The integrated compressed air preparation system traps incidental condensate and cleans the compressed air of particles such as rust and dust. This ensures the required compressed air quality (for MPN-LCV air class 3.4.3, for MPN-PVM air class 2.4.2 or 2.3.2) according to ISO 8573-1:2010.

The anti-trapping protection can be used to reduce the risk of crushing in the area of the valve or sensor plungers.

The anti-trapping protection can be attached to the special carbide washer supplied and consequently can also be retrofitted to existing systems. It can be removed without damage for maintenance work.

To protect the valves in contaminated environments.

ELECTRONIC LEVEL CONTROL SYSTEMS

ELECTRONIC-PNEUMATIC LEVEL CONTROL SYSTEMS FOR COMBINATION WITH BIAIR[®] MEMBRANE AIR SPRINGS, FOR OPTIMISED POSITIONING ACCURACY AND REDUCTION OF DEFLECTION



All information about our electronic level control systems can also be found on our website.

NOTES

- Electronic pneumatic level control systems are suitable for combination with BiAir[®] membrane air springs.
- The use of an intelligent standard algorithm and electronic valves with flow rates of up to 1000 l/min allow significantly reduced deflections and settling times compared to mechanical-pneumatic level control systems.
- The Bilz electronic pneumatic level control systems are ideally suited for use with high-precision machines, highly dynamic and vibration-sensitive measuring machines as well as testing and production machines.

ELECTRONIC PNEUMATIC POSITION CONTROL EPPC[™]



Description

- The Electronic Pneumatic Position Control EPPC[™] offers optimum vibration insulation and levelling for highly dynamic and vibration-sensitive machines and instruments.
- The EPPC[™] can be combined with three or six BiAir[®] membrane air spring control groups to control up to six degrees of freedom. Bilz offer a wide range of different size air springs for system design.

The powerful electronics, consisting of a 14bit AD converter and 16bit signal processor, are integrated into the pressure control valves and thus ensure almost noise-free control. Losses (pressure drops) within the hose connections are minimised by directly connecting the pressure control valves to the respective air springs. The use of CAN bus technology means that the control unit can be installed up to 20 m away. The EPPC[™] is consequently suitable for use in sensitive environments such as clean rooms or laboratories.



SYSTEM INSTALLATION

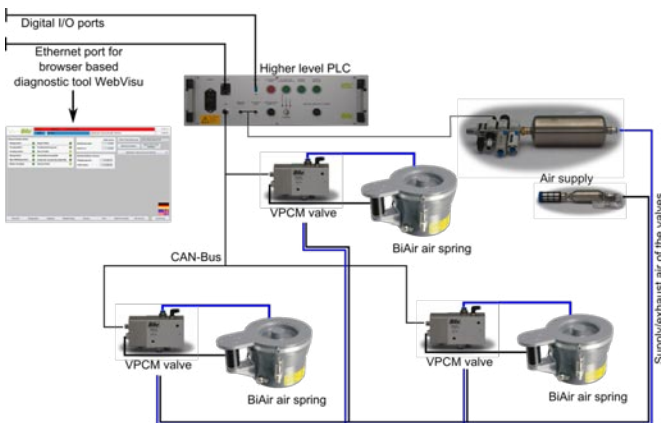

Information about graphic

Theoretical vibration curve of a mechanical-pneumatic level control system (MPN) compared to the EPPC™. At a deflection of $-80 \mu\text{m}$, the MPN reaches a stable position within $\pm 15 \mu\text{m}$ after approx. 0.75 seconds. With the EPPC™, the deflection time is reduced by approx. 45 % to 0.4 seconds.

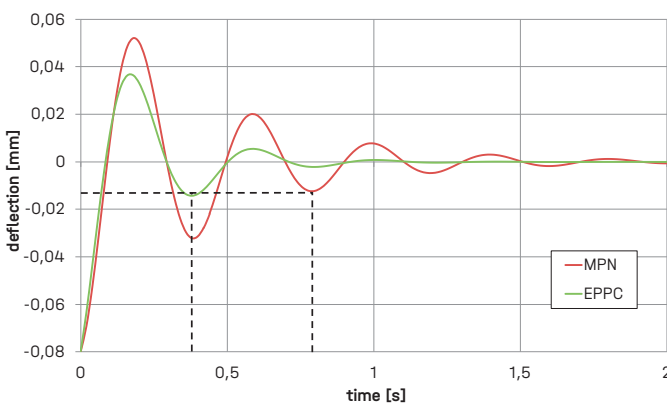

Properties

- Optimum positional accuracy ($\pm 10 \mu\text{m}$).
- Individually adjustable system parameters (such as insulation).
- Short deflection and settling times in response to load changes.
- One high-performance servo valve and one displacement sensor per degree of freedom.
- Optimised connecting system using CAN bus technology.
- Intelligent browser-based user interface for setting, diagnostics and monitoring, connection via Ethernet, remote maintenance possible.
- Operator status display (e.g. ready, working position, motion complete, error).
- Digital I/O interfaces for external control and monitoring.
- Noise-free control due to high-resolution signal processing and servo-valve technology.
- Robust and proven air spring technology, can be combined with Bilz BiAir® membrane air springs.
- No disturbing heat generation, magnetic field fluctuations or high power consumption as in electromagnetic actuators.

TECHNICAL DATA OVERVIEW

Typical system load*	800 kg - 120.000 kg
Vertical natural frequencies*	1.2 - 2.5 Hz
Horizontal natural frequencies*	2,2 - 2,8 Hz
Type of control	Servo-pneumatic
Clean room suitable	yes
Communication interfaces	Ethernet, Digital I/O

SENSOR RESOLUTION:

Displacement measuring system	0,76 μm
Pressure sensor	0,36 mbar
Sampling rate sensor signal	1 kHz (after oversampling)

*Customised modifications possible

ACTIVE VIBRATION INSULATION

SYSTEMS FOR ACTIVE VIBRATION INSULATION WITH POWERFUL REAL-TIME CONTROL IN UP TO 6 DEGREES OF FREEDOM AND THE HIGHEST DEMANDS ON INSULATING EFFECT, SETTING TIME AND LEVELLING CONSTANCY.



All information about our active vibration isolation is also available on our website.

Active vibration insulators generate a counter-force phase-shifted by 180° using a suitable control system, in which the insulators act as actuators at the same time. Moreover, the resonance amplification in the natural frequency range of the insulators is minimised.

NOTES

In active vibration insulation, the system response is improved by the use of actively controlled elements (actuators). This achieves improved system properties compared to purely passive insulators. There are two insulator properties that are affected by this:

The vibration insulation and the dynamic response after excitation by forces and disturbances.

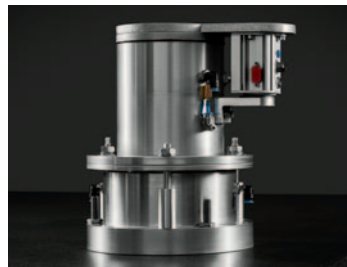

AIS™ ACTIVE ISOLATION SYSTEM

Active electronic-pneumatic vibration insulation with 3 or 6 degrees of freedom.

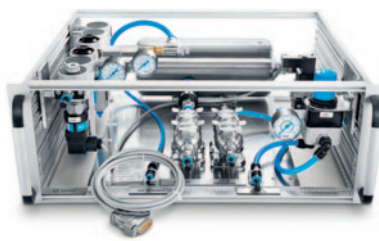

The modular system operates without disturbing heat generation, magnetic field fluctuations or high power consumption.

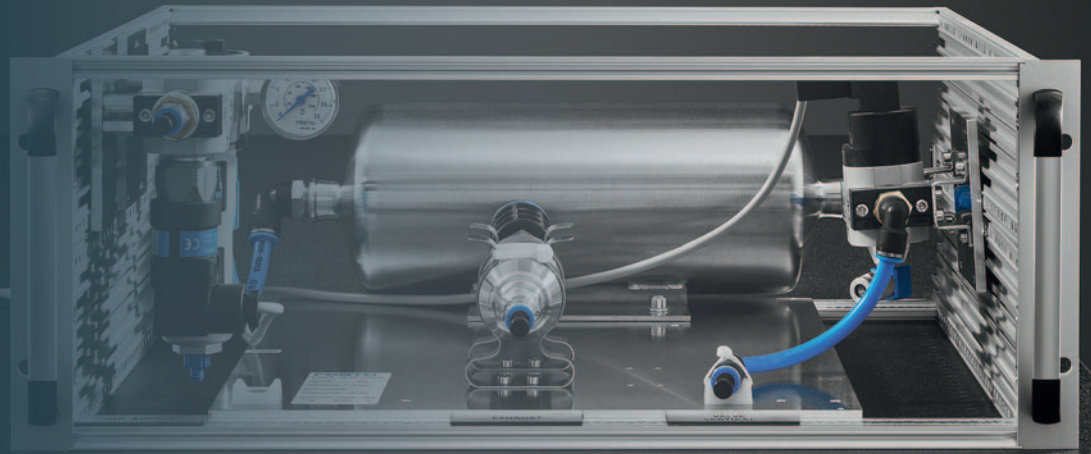

- With the AIS™ Active insulation System, active control significantly improves vibration insulation by suppressing amplification at resonance without degrading properties at higher frequencies. In this process, the AIS™ maintains its active properties over the entire working travel (stroke) of the air spring.
- In dynamic applications, the active response of the system ensures reduced deflection times after excitation. The system is consequently quicker at rest and in measuring tasks with positioning movements achieves shorter cycle times than passive systems.
- The special feature of the system is the pneumatic actuator principle, which hoods a wide dynamic working range - even in the case of very heavy machines. Control bandwidths up to the 300 Hz range are possible due to extremely fast-reacting valves. The system reacts in real time and consequently so quickly that no feed-forward signal control is necessary.
- **The AIS™ can be used with three or six actively controlled degrees of freedom (DOF).** The system can be adapted to the different application requirements. Three vertically aligned controllers are used with three regulated degrees of freedom, which actively regulate the vertical position and the rotations around both horizontal axes. The other degrees of freedom are passively reset by the membranes.
- With the use of 6 controlled degrees of freedom, the HAB horizontal air springs are also used. In this configuration, six controllers are arranged both vertically and horizontally.

AIS™ High Performance

- Additional BiAir air springs rotated by 90° are used in the AIS™ High Performance version to generate higher horizontal counter forces. The horizontal HAB air springs act purely as air bearings. This eliminates even minor friction effects and influences of the membrane.

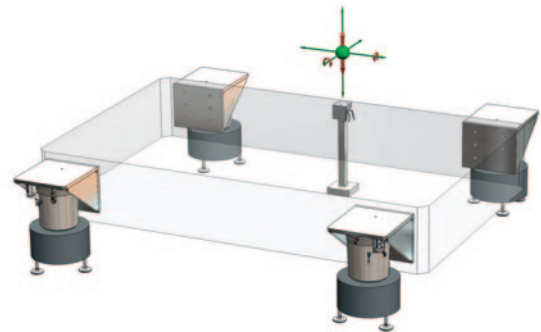

4-point AIS™ for 3 (3 DOF) actively controlled degrees of freedom

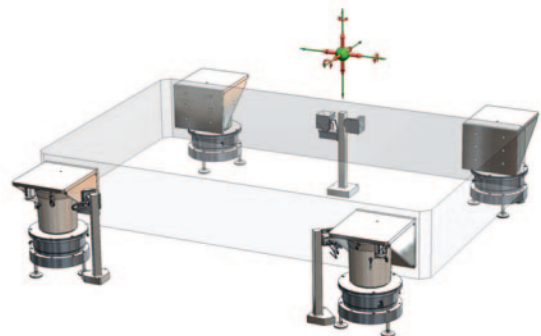

4-point AIS™ for 6 (6 DOF) actively controlled degrees of freedom

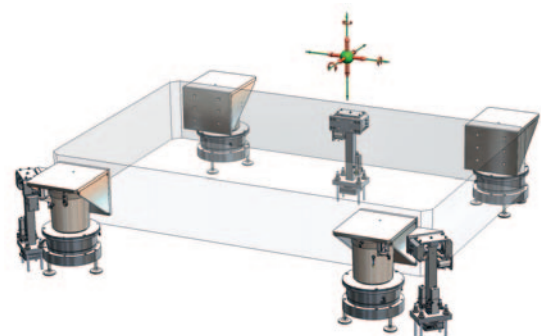

4-point AIS™ High Performance for 6 actively controlled degrees of freedom

SYSTEM INSTALLATION AIS™

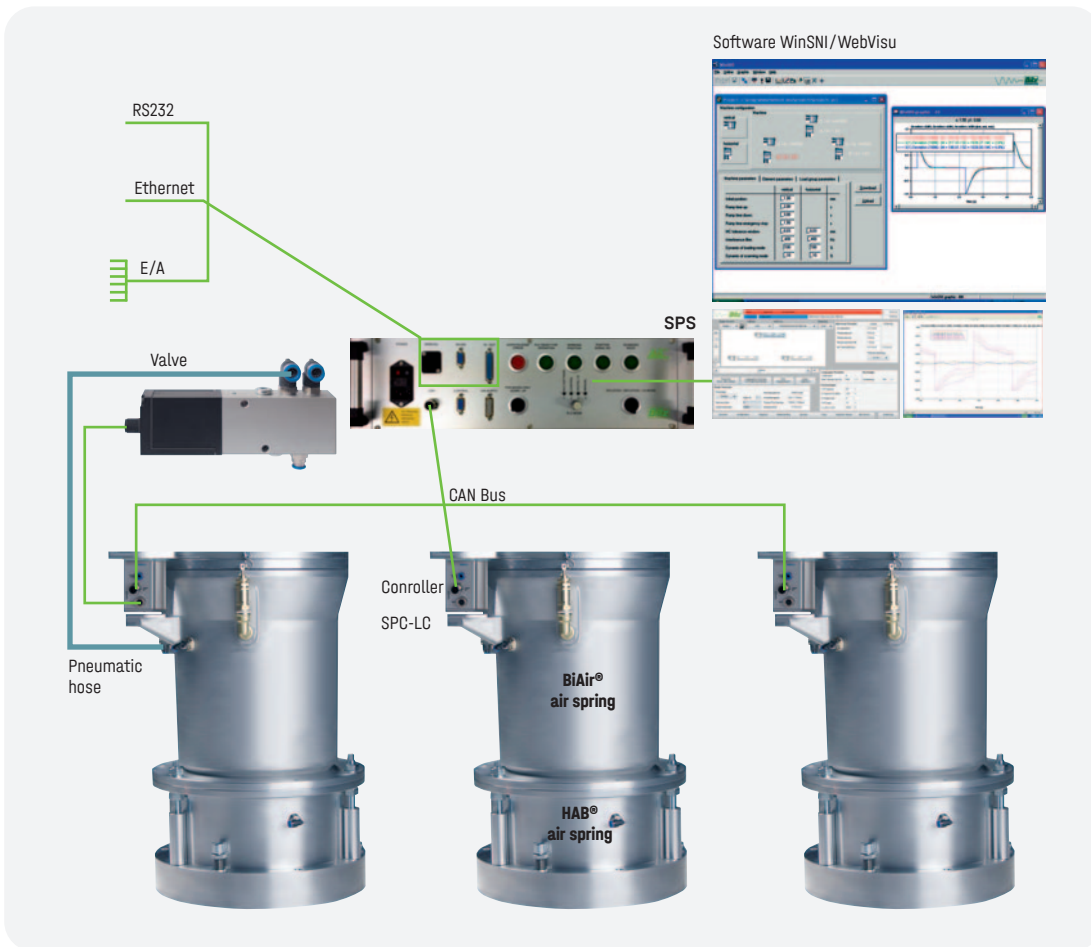

System installation
Active Vibration
insulation AIS™
(schematic
representation)

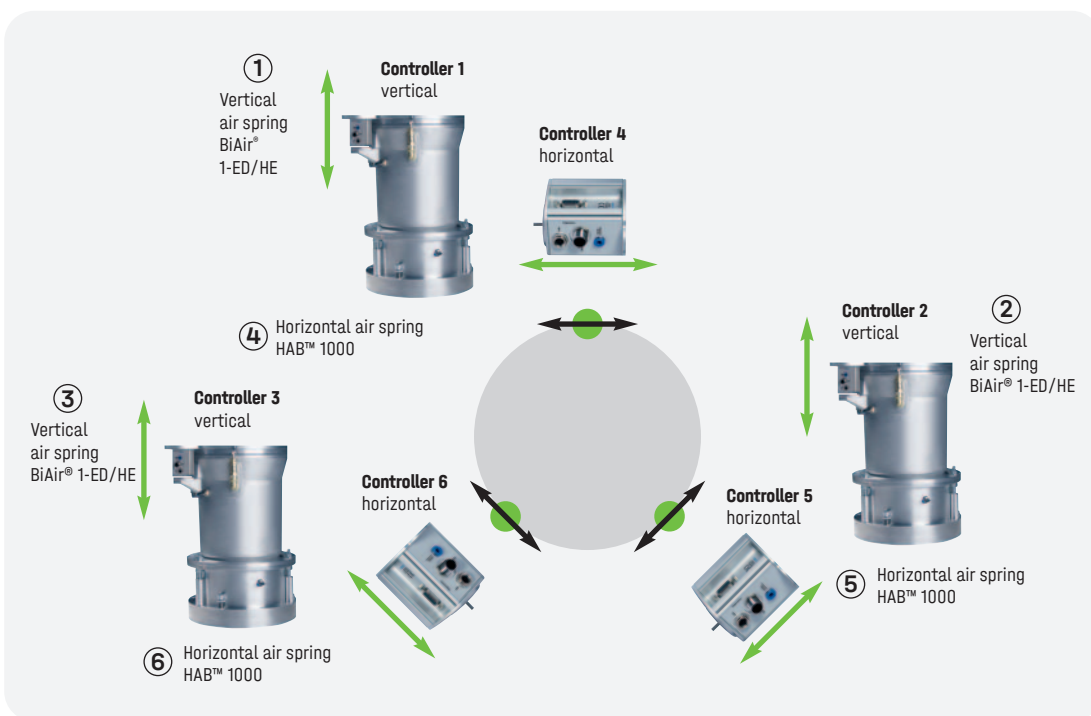

Arrangement of
the controllers
for a 6 DOF AIS™

Properties

- Active electronic-pneumatic vibration insulation with up to 6 controlled degrees of freedom.
- Can also be retrofitted from 3 to 6 DOF using spacers.
- Highly effective vibration insulation, nearly without resonance amplification.
- Optimal positioning precision in vertical and horizontal plane.
- Minimal deflection and subsidence times when machine changes loads.
- Highly effective real-time control.
- PLC, CAN bus and one control per degree of freedom and highly dynamic proportional position control valve.
- Each control unit has a microprocessor and integrated, high-resolution sensor technology for position, pressure and acceleration.
- Easy-to-use, intelligent software for commissioning and diagnostics.
- Simple digital switching between scanning mode (during sensitive machine operations) and loading mode (during machine load changes).
- No feed-forward signal required.
- In contrast to electro-magnetic actuators or linear motors, no generation of heat or magnetic fields which could disturb machine operation.

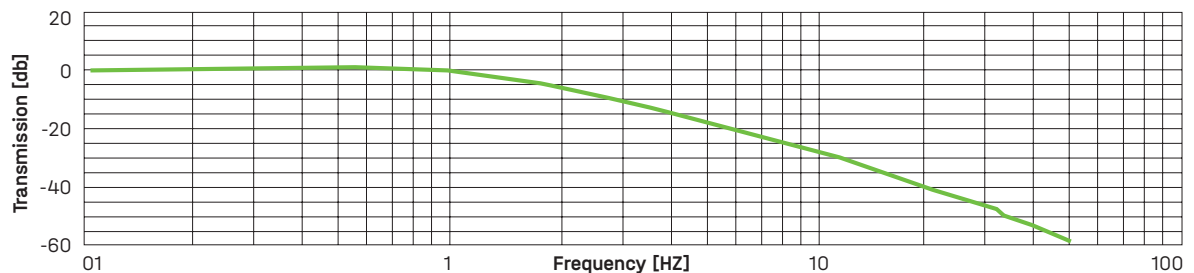

Transmission function AIS™ (interpolated system measurement on shaker test bench)

OVERVIEW OF TECHNICAL DATA AIS™

	AIS™ 3 degrees of freedom	AIS™ 6 degrees of freedom	AIS™ High Performance 6 degrees of freedom
Typical system load*	800 kg - 120.000 kg	800 kg - 120.000 kg	800 kg - 120.000 kg
Vertical natural frequencies*	1,2 - 2,5 Hz	1,2 - 2,5 Hz	1,2 - 2,5 Hz
Horizontal natural frequencies	2,2 - 2,8 Hz	1,1 - 1,9 Hz	0,8 - 1,9 Hz
Type of control	Servo-pneumatic	Servo-pneumatic	Servo-pneumatic
Actively controlled frequency	0-15 Hz	0-15 Hz	0-15 Hz
Clean room suitability	ja	ja	ja
Communication interfaces	Ethernet, Digital I/O, RS232	Ethernet, Digital I/O, RS232	Ethernet, Digital I/O ,RS232

SENSOR RESOLUTION:

Route measuring system	0,2 µm	0,2 µm	0,2 µm
Accelerometer	8 µg	8 µg	8 µg
Pressure sensor	0,2 mbar	0,2 mbar	0,2 mbar
Sampling rate sensor signals	4 kHz (after oversampling)	4 kHz (after oversampling)	4 kHz (after oversampling)

TABLE PLATFORMS

VIBRATION INSULATING TABLE PLATFORMS WITH INTEGRATED AIR SPRING IN A STURDY METAL HOUSING. OPTIONALLY AVAILABLE WITH MECHANICAL-PNEUMATIC LEVEL CONTROL.



All information about our table platforms is also available on our website.

Mobile table platforms with passive insulation systems, with or without level control or air pressure supply.

NOTES

VITAP® vibration insulating platforms are made of a robust, powder-coated aluminium housing with integrated Bilz FAEBI® rubber air springs or Bilz BiAir® membrane air springs.

Depending on the variant, they are optionally equipped with simple to convenient Bilz position or level control systems and are available with or without connection to an external compressed air supply.

A polished hard stone pad lies on the insulators as a support base and solid base mass.

APPLICATION AREAS:

- Only in conjunction with a rigid base/table
- For light and small measuring or testing equipment weighing up to 200 kg.
- Optical devices, microscopes, small surface roughness and roundness measuring equipment, hardness testers, analytical balances, etc.
- Also suitable for portable use of these measuring devices.
- Applications in industrial production environments, laboratories and measuring rooms up to clean rooms.



Bilz VITAP® with Olympus microscope

PASSIVE TABLE PLATFORMS

SERIES VITAP-F



Mobile and autonomous, passive table platform, no compressed air and power supply necessary.

- Load capacity 600 - 1,300 N
- Vertical natural frequency 4.5 - 6 Hz

Colour: RAL 7037, dusty grey

The VITAP-F table platform is a variant with tried and tested FAEBI® rubber air springs and non-return valves (autovalves). No connection to an external compressed air supply is necessary. A hand pump is included.

Series	Item no.	Dimension platformbox mm	Dimension installation area mm	Height mm	Load Capacity N	Natural frequency Hz	Compressed air supply
F 50-40	56-0008	540 × 440	500 × 400	100 +/- 1,5	600	4,5-6	self-sufficient / air pump
F 60-50	56-0009	640 × 540	600 × 500	100 +/- 1,5	1.300	4,5-6	self-sufficient / air pump

SERIES VITAP-FP



Mobile, passive table platform with convenient level adjustment, requires no power supply.

- Load capacity 600 - 1,300 N
- Vertical natural frequency 4.5 - 6 Hz

Colour: RAL 7037, dusty grey

The VITAP-FP table platform is a variant with tried and tested FAEBI® rubber air springs and fine pressure regulators for convenient height adjustment. A connection to an external compressed air supply is available.

Series	Item no.	Dimension platformbox mm	Dimension installation area mm	Height mm	Load Capacity N	Natural frequency Hz	Compressed air supply
FP 50-40	56-0010	540 × 440	500 × 400	105 +/- 1,5	600	4,5-6	4 bar / compressed air net
FP 60-50	56-0011	640 × 540	600 × 500	105 +/- 1,5	1.300	4,5-6	4 bar / compressed air net

SERIES VITAP-BM



Mobile, passive table platform with mechanical-pneumatic level control and high insulation efficiency. No power supply necessary.

- Load capacity 750 - 2.000 N
- Vertical natural frequency 3 Hz

Colour: RAL 7037, dusty grey

VITAP-BM vibration insulated table platform is a variant with highly effective BiAir® membrane air springs and mechanical-pneumatic level control (MPN) with automatic level compensation in response to load changes. A connection to an external compressed air supply is available.

Series	Item no.	Dimension platformbox mm	Dimension installation area mm	Height mm	Load Capacity N	Natural frequency Hz	Compressed air supply
BM 50-40a	56-0006	540 × 440	500 × 400	98 +/- 1,5	750	3	6 bar / compressed air net
BM 50-40b	56-0005	540 × 440	500 × 400	98 +/- 1,5	1.500	3	6 bar / compressed air net
BM 60-50a	56-0002	640 × 540	600 × 500	98 +/- 1,5	1.500	3	6 bar / compressed air net
BM 60-50a	56-0003	640 × 540	600 × 500	98 +/- 1,5	2.000	3	6 bar / compressed air net

VIBRATION-INSULATED TABLES

LABORATORY TABLES FOR THE INSULATION OF INTERFERING ENVIRONMENTAL VIBRATIONS FOR WORKING ON HIGHLY SENSITIVE EQUIPMENT.



All information about our vibration-insulated tables is also available on our website.

Our laboratory tables are vibration-insulated work places that can be used, for example, as microscope tables and are available with a hard stone (model LTH) or optical table top (model LTO).

Disturbing vibrations from the environment are insulated through highly effective membrane air spring insulators. At the same time, the mechanical-pneumatic level control ensures that the level ($\pm 1/10\text{mm}$ as standard or $\pm 1/100\text{mm}$ as an option) is retained even with load changes.

A maintenance unit is also included, which is connected upstream for compressed air conditioning.

NOTES

- LTH with hard stone as intrinsic solid base and additional mass for ideal vibration insulation
- LTO with optical pad for flexible attachment of attachments (e.g. optics)

TAILORED TO YOUR APPLICATIONS

Individual requirements vary greatly depending on the application, particularly in the area of laboratory tables. There is a wide range of possible special designs available in terms of dimensions, potential load-bearing capacities, materials, insulating efficiency and equipment.

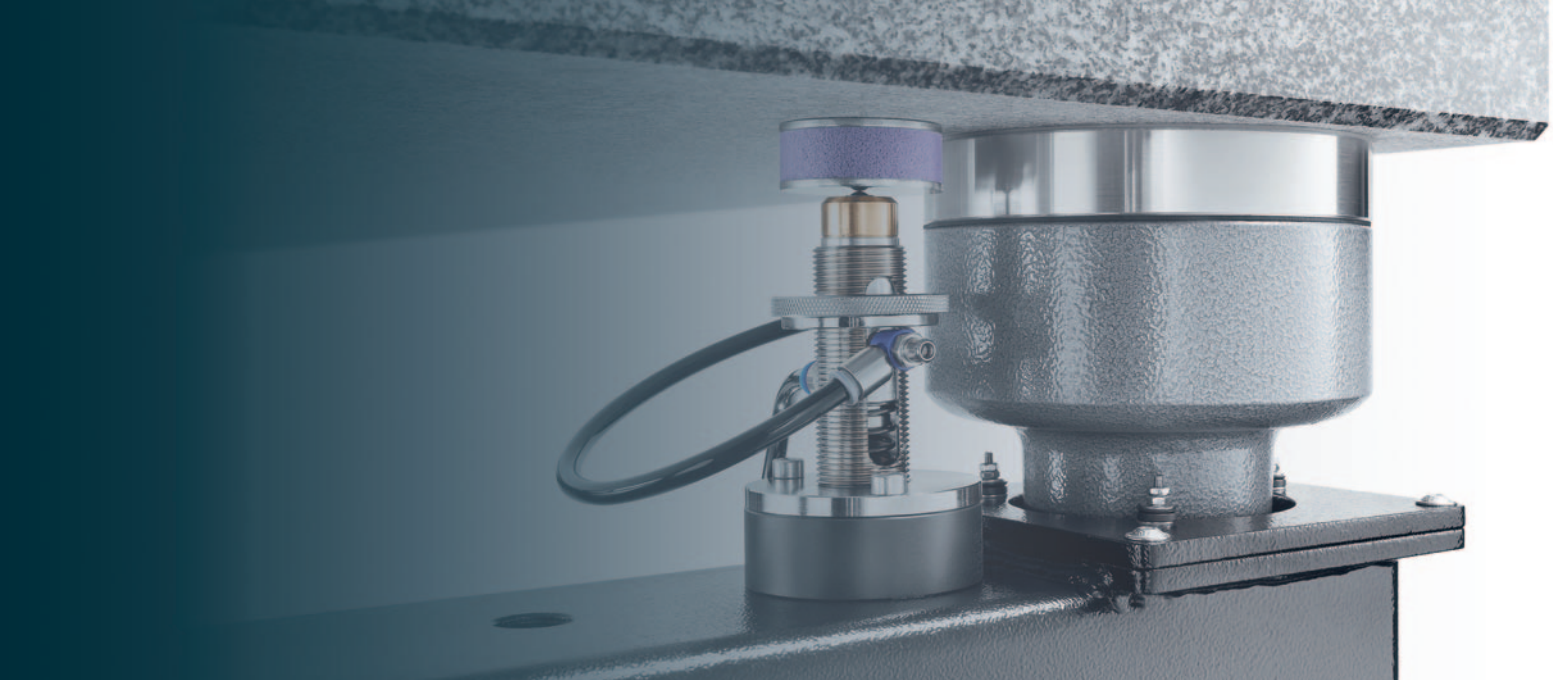

Versions

Various underframes
in standard and special sizes

Protective
cover

Arm rests

Various materials (wood, metal)
and lacquering for:

- Doors
- Floor slab/intermediate floors
- Housing

Wooden pad:

- Various sizes
- Sections
- Rounded corners

Holders for
monitor, keyboard,
mouse, etc.

Rolls

Levelling elements

Profiles and brackets for
additional components

Lacquering in RAL colours

EXAMPLES FOR OPTIONAL EQUIPMENT:

- Special sizes
- Mechanical or electronic level control
- Membrane air springs or rubber air spring
- Insulator optionally integrated in the underframe hood bonnets
- Drawers
- Arm rests
- Holders for PC, monitor, keyboard etc.
- Additional holes/threads in tabletop or subframe
- Profiles and brackets for additional components
- Castors or levelling elements
- Various materials and finishes for doors, enclosure, shelves etc.

Please get in touch, we are happy to provide advice on the configuration of your tailor-made, vibration-isolated table.

LABORATORY TABLES WITH HARD STONE TOP

and membrane air springs for effective vibration insulation.

The Bilz laboratory tables LTH are extremely robust, resistant and vibration-insulated tables and work places with a massive hard stone pad. They are used in all applications where vibrations and/or changes in level are to be avoided to enable the measurement, experiment or work to be performed with the utmost precision.

LABORATORY TABLE LTH (HARD STONE) WITH BIAIR[®]-ED



Description

- Adjustable table feet.
- Rigid, welded steel subframe, powder-coated.
- BiAir[®]-ED membrane air spring insulators (**vertical natural frequency 2.5 - 3 Hz**) between subframe and table top.
- Mechanical-pneumatic level control systems (reset accuracy $\pm 1/10\text{mm}$ or $\pm 1/100\text{mm}$, depending on the valve used).
- Table top made from hard stone with a ground finish.
- Choice of colour according to customer requirements.

We specialise in custom solutions.

Please get in touch. We are always happy to offer our advice.

We also offer the following **standard sizes**:

Type	Item no.	Width mm	Depth mm	Thickness hard stone mm	Working height mm	max. load N
LTH 60-50	55-0011	600	500	100	760	2.500
LTH 80-60	55-0022	800	600	120	760	2.500
LTH 100-63	55-0007	1.000	630	100	760	3.200
LTH 90-75	55-0012	900	750	100	760	3.200
LTH 100-80	55-0008	1.000	800	140	760	7.000
LTH 100-100	55-0006	1.000	1.000	160	760	7.000
LTH 120-80	55-0021	1.200	800	160	760	7.000
LTH 150-100	55-0009	1.500	1.000	190	760	18.000
LTH 200-100	55-0010	2.000	1.000	220	760	28.000

Application area:

- Vibration-sensitive measuring and testing equipment
- Electronic devices
- Scales
- Medical

Colour: RAL 9005, deep black

LABORATORY TABLE LTH (HARD STONE) WITH BIAIR®-OC



Application area :

- As for laboratory table LTH with BiAIR-ED.
- Best suited for low dynamic applications requiring excellent insulation performance.

Colour: RAL 9005, deep black

Description

- Adjustable table feet.
- Rigid, welded steel subframe, powder-coated.
- BiAir®-OC membrane air spring insulators (**vertical natural frequency 2 Hz**) between subframe and table top.
- Mechanical-pneumatic level control systems (reset accuracy $\pm 1/10\text{mm}$ or $\pm 1/100\text{mm}$, depending on the valve used).
- Table top made from hard stone with a ground finish.
- Choice of colour according to customer requirements.

We specialise in custom solutions.

Please get in touch. We are always happy to offer our advice.

We also offer the following **standard sizes**:

Type	Width mm	Depth mm	Thickness hard stone mm	Working height mm	max. load N
LTH 60-50-OC	600	500	100	760	2.500
LTH 80-60-OC	800	600	120	760	2.500
LTH 100-63-OC	1.000	630	100	760	3.200
LTH 90-75-OC	900	750	100	760	3.200
LTH 100-80-OC	1.000	800	140	760	7.000
LTH 100-100-OC	1.000	1.000	160	760	7.000
LTH 120-80-OC	1.200	800	160	760	7.000

LABORATORY TABLE LTH (HARD STONE) WITH BIAIR®-PAS



Application area :

- As for laboratory table LTH with BiAIR-ED.
- Ideally suited for applications with low dynamics and high requirements for vibration insulation, particularly in the horizontal plane.

Colour: RAL 9005, deep black

Description

- Adjustable table feet.
- Rigid, welded steel subframe, powder-coated.
- BiAir®-PAS membrane air spring insulators (**vertical natural frequency approx. 2 Hz, horizontal approx. 1.2 Hz**) between subframe and table top.
- Mechanical-pneumatic level control systems (reset accuracy $\pm 1/10\text{mm}$ or $\pm 1/100\text{mm}$, depending on the valve used).
- Table top made from hard stone with a ground finish.
- Choice of colour according to customer requirements.

We specialise in custom solutions.

Please get in touch. We are always happy to offer our advice.

We also offer the following **standard sizes**:

Type	Width mm	Depth mm	Thickness hard stone mm	Working height mm	max. load N
LTH 60-50-PAS	600	500	100	760	2.500
LTH 80-60-PAS	800	600	120	760	2.500
LTH 100-63-PAS	1.000	630	100	760	3.200
LTH 90-75-PAS	900	750	100	760	3.200
LTH 100-80-PAS	1.000	800	140	760	7.000
LTH 100-100-PAS	1.000	1.000	160	760	7.000
LTH 120-80-PAS	1.200	800	160	760	7.000

LABORATORY TABLES WITH OPTICAL PAD

and membrane air springs for effective vibration insulation.

Bilz optical work places are distinguished by their excellent quality and functionality. The honeycomb pads are optimised with regard to their insulation response so that the usually high resonance amplitude in the higher frequency range are attenuated by the tables in the HD/HDT model series by their inherent insulation.

- HD steel honeycomb core with high natural insulation, hood pad **without** thread insert
- HDT steel honeycomb core with high natural insulation, hood pad **with** thread inserts

LABORATORY TABLE LTO (OPTICAL PAD) WITH BIAIR®-ED



Application area:

- Vibration-sensitive measuring and testing equipment
- Optical and electronic devices
- Laser devices
- Electronic devices
- Scales
- Medical instruments

Colour: RAL 9005, deep black

Description

- Adjustable table feet.
- Rigid, welded steel subframe, powder-coated.
- BiAir®-ED membrane air spring insulators (**vertical natural frequency 2.5 - 3 Hz**) between subframe and table top.
- Mechanical-pneumatic level control systems (reset accuracy $\pm 1/10\text{mm}$ or $\pm 1/100\text{mm}$, depending on the valve used).
- Optical table tops:
 - HD steel honeycomb core with high natural insulation, hood pad without thread insert
 - HDT steel honeycomb core with high natural insulation, hood pad with thread inserts
 - Also available in a suitable clean room version with stainless steel base pad.
- Choice of colour according to customer requirements.

We specialise in custom solutions.

Please get in touch. We are always happy to offer our advice.

We also offer the following **standard sizes**:

Type	Width mm	Depth mm	Thickness mm	Working height mm	max. load N
LTO 90-75	900	750	100	760	2.000
LTO 120-60	1.200	600	100	760	3.000
LTO 150-90	1.500	900	100	760	5.000
LTO 200-100	2.000	1.000	200	760	5.000
LTO 240-120	2.400	1.200	200	760	7.500
LTO 300-150	3.000	1.500	300	760	7.500

LABORATORY TABLE LTO (OPTICAL PAD) WITH BIAIR®-OC



Application area:

- As for laboratory table LTO with BiAIR-ED.
- Best suited for low dynamic applications requiring excellent insulation performance.

Colour: RAL 9005, deep black

Description

- Adjustable table feet.
- Rigid, welded steel subframe, powder-coated.
- BiAir®-OC membrane air spring insulators (vertical natural frequency 2 Hz) between subframe and table top.
- Mechanical-pneumatic level control systems (reset accuracy $\pm 1/10\text{mm}$ or $\pm 1/100\text{mm}$, depending on the valve used).
- Optical table tops:
 - HD steel honeycomb core with high natural insulation, hood pad without thread insert
 - HDT steel honeycomb core with high natural insulation, hood pad with thread inserts
 - Also available in a suitable clean room version with stainless steel base pad.
- Choice of colour according to customer requirements.

We specialise in custom solutions.

Please get in touch. We are always happy to offer our advice.

We also offer the following **standard sizes**:

Type	Width mm	Depth mm	Thickness mm	Working height mm	max. load N
LTO 90-75	900	750	100	760	2.000
LTO 120-60	1.200	600	100	760	3.000
LTO 150-90	1.500	900	100	760	5.000
LTO 200-100	2.000	1.000	200	760	5.000
LTO 240-120	2.400	1.200	200	760	7.500
LTO 300-150	3.000	1.500	300	760	7.500

LABORATORY TABLE LTO (OPTICAL PAD) WITH BIAIR®-PAS



Application area:

- As for laboratory table LTO with BiAIR-ED.
- Ideally suited for applications with low dynamics and high requirements for vibration insulation, particularly in the horizontal plane.

Colour: RAL 9005, deep black

Description

- Adjustable table feet.
- Rigid, welded steel subframe, powder-coated.
- BiAir®-PAS membrane air spring insulators (vertical natural frequency approx. 2 Hz, horizontal approx. 1.2 Hz) between subframe and table top.
- Mechanical-pneumatic level control systems (reset accuracy $\pm 1/10\text{mm}$ or $\pm 1/100\text{mm}$, depending on the valve used).
- Optical table tops:
 - HD steel honeycomb core with high natural insulation, hood pad without thread insert
 - HDT steel honeycomb core with high natural insulation, hood pad with thread inserts
 - Also available in a suitable clean room version with stainless steel base pad.
- Choice of colour according to customer requirements.

We specialise in custom solutions.

Please get in touch. We are always happy to offer our advice.

We also offer the following **standard sizes**:

Typ	Width mm	Depth mm	Thickness mm	Working height mm	max. load N
LTO 90-75	900	750	100	760	2.000
LTO 120-60	1.200	600	100	760	3.000
LTO 150-90	1.500	900	100	760	5.000
LTO 200-100	2.000	1.000	200	760	5.000
LTO 240-120	2.400	1.200	200	760	7.500
LTO 300-150	3.000	1.500	300	760	7.500

COMPANY HEADQUARTERS

THE HEADQUARTERS OF BILZ VIBRATION TECHNOLOGY AG ARE IN LEONBERG NEAR STUTTGART.



OUR SALES PARTNERS:

You can find our sales partners in Germany and around the world on our website:

LEONBERG



WHAT CAN WE DO FOR YOU?

Do you have any questions about Bilz Vibration Technology AG in Leonberg near Stuttgart or a specific career or product enquiry? Whatever it is - we look forward to seeing you!

THIS IS HOW YOU CAN REACH US:

Use our contact form at <https://www.bilz.ag> to send us an enquiry, or otherwise call us.

Quick help: +49 7152 30 91-0 Contact: info@bilz.ag Services: service@bilz.ag

Bilz[®] | Focused
on Partnership

Bilz Vibration Technology AG

Böblinger Straße 25
D-71229 Leonberg

Fon +49 7152 3091-0
Fax +49 7152 3091-10

info@bilz.ag
www.bilz.ag



Product catalogue | EN